

Water solutions

Small Devices, Big Impact.



Visit us at
[belimo.com](https://www.belimo.com)

BELIMO[®]

| | | |
|----------|---|-----------|
| 1 | Zone valves | 3 |
| 2 | Pressure-independent characterised control valves | 11 |
| 3 | Characterised control valves | 17 |
| 4 | Globe valves | 23 |
| 5 | Ball valves | 33 |
| 6 | Butterfly valves | 39 |
| | Definitions | 59 |

1

BELIMO
ZoneTight™

Zone valves

Maximum comfort, minimum consumption

Zone Valve

| | | | |
|-------------------------------|-----------------|------------------|---|
| 2-way/3-way zone valve (Z..S) | Internal thread | PN 20 / DN 15-25 | 4 |
|-------------------------------|-----------------|------------------|---|

ZoneTight™

| | | | |
|--|-----------------|------------------|---|
| 2-way zone valve (QCV) | Internal thread | PN 25 / DN 15-20 | 5 |
| 3-way change-over ball zone valve (QCV) | | | 6 |
| Pressure-independent characterised control valve (PIQCV) | Internal thread | PN 25 / DN 15-25 | 7 |
| Pressure-independent flow limiter valve (PIFLV) | Internal thread | PN 25 / DN 15-25 | 8 |

Thermostat

| | | |
|------------|-----------------------------|---|
| Digital | 2-pipe / 4-pipe application | 9 |
| Mechanical | 2-pipe application | 9 |

DN 15–25



| | |
|--------------------|---|
| Media | Cold and hot water with up to max. 50% glycol |
| Medium temperature | 0...93°C |
| Pipe connection | BSP |



Z2..S..



Z3..S..

Suitable Actuators

| Open-close | Nominal voltage | Fail-safe function | Running time motor | Running time emergency control function | DN 15 | | DN 20 | | DN 25 | |
|------------|-----------------|--------------------|--------------------|---|-----------------|------------|-----------------|------------|-----------------|------------|
| | | | | | k_{vs} [m³/h] | Valve type | k_{vs} [m³/h] | Valve type | k_{vs} [m³/h] | Valve type |
| 2-way | | | | | 1.7 | Z215S.. | 2.2 | Z220S.. | 2.6 | Z225S.. |
| 3-way | | | | | 2.2 | Z315S.. | 2.6 | Z320S.. | 3 | Z325S.. |

| Actuator type | Δp_s [kPa] | Δp_s [kPa] | Δp_s [kPa] |
|-----------------------------|--------------------|--------------------|--------------------|
| Standard actuators | | | |
| • 24 V • 13...18s • 4...5s | Z215S-24 | 414 | |
| • 230 V • 13...18s • 4...5s | Z215S-230 | 414 | |
| • 120 V • 13...18s • 4...5s | Z215S-120 | 414 | |
| • 24 V • 13...18s • 4...5s | Z220S-24 | | 344 |
| • 230 V • 13...18s • 4...5s | Z220S-230 | | 344 |
| • 120 V • 13...18s • 4...5s | Z220S-120 | | 344 |
| • 24 V • 13...18s • 4...5s | Z225S-24 | | 303 |
| • 230 V • 13...18s • 4...5s | Z225S-230 | | 303 |
| • 24 V • 13...18s • 4...5s | Z315S-24 | 414 | |
| • 230 V • 13...18s • 4...5s | Z315S-230 | 414 | |
| • 24 V • 13...18s • 4...5s | Z320S-24 | | 344 |
| • 230 V • 13...18s • 4...5s | Z320S-230 | | 344 |
| • 24 V • 13...18s • 4...5s | Z325S-24 | | 303 |
| • 230 V • 13...18s • 4...5s | Z325S-230 | | 303 |

DN 15 / DN 20



| | |
|---------------------|---|
| Media | Cold and hot water with up to max. 50% glycol |
| Medium temperature | 2...100°C 2...90°C (with actuator) |
| Pipe connection | Internal thread Rp (ISO 7-1) |
| Flow characteristic | A-AB, equal percentage |
| Leakage rate | Leakage rate A, tight (EN 12266-1) |



Suitable Actuators

| Nominal torque | Open-close | 3-point | Modulating (2...10 VDC) | MP-Bus® communication | BACnet communication | Fail-safe function | Nominal voltage AC/DC 24 V AC 230 V | Running time motor | DN 15 | | DN 20 | | DN 25 | |
|----------------|------------|---------|-------------------------|-----------------------|----------------------|--------------------|-------------------------------------|--------------------|-----------------|------------|-----------------|------------|-----------------|------------|
| | | | | | | | | | k_{vs} [m³/h] | Valve type | k_{vs} [m³/h] | Valve type | k_{vs} [m³/h] | Valve type |
| 0.09–1.2 | | | | | | | | | 0.5–8 | C220Q-K | 0.5–7 | C225Q-K | | |
| 0.4–4.8 | | | | | | | | | | | | | | |

| Actuator type | Δp_s [kPa] | $\Delta p_{max}^{1)}$ [kPa] | Δp_s [kPa] | $\Delta p_{max}^{1)}$ [kPa] | Δp_s [kPa] | $\Delta p_{max}^{1)}$ [kPa] |
|-------------------------------------|--------------------|-----------------------------|--------------------|-----------------------------|--------------------|-----------------------------|
| Standard actuators | | | | | | |
| 1 Nm • 24 V • 75 s | CQ24A | 520 | 280 | 520 | 280 | 520 |
| | CQ24A-SR | 520 | 280 | 520 | 280 | 520 |
| | CQ24A-MPL | 520 | 280 | 520 | 280 | 520 |
| | CQ24A-BAC | 520 | 280 | 520 | 280 | 520 |
| | CQ230A | 520 | 280 | 520 | 280 | 520 |
| Actuator with fail-safe function NC | | | | | | |
| 1 Nm • 24 V • 75 s | CQK24A | 520 | 280 | 520 | 280 | 520 |
| | CQK24A-SR | 520 | 280 | 520 | 280 | 520 |
| | CQK230A | 520 | 280 | 520 | 280 | 520 |
| 2.5 Nm • 24 V | TQF24 | 520 | 280 | 520 | 280 | 520 |
| | TQF230 | 520 | 280 | 520 | 280 | 520 |
| Fast runners | | | | | | |
| 1 Nm • 230 V • 35 s | CQC230A | 520 | 280 | 520 | 280 | 520 |

¹⁾ Low noise operation $\Delta P_{max} = 50kPa$

DN 15 / DN 20



| | |
|--------------------|---|
| Media | Cold and hot water with up to max. 50% glycol |
| Medium temperature | 2...100°C 2...90°C (with actuator) |
| Pipe connection | Internal thread Rp (ISO 7-1) |
| Leakage rate | Leakage rate A, tight (EN 12266-1) |



DN 15-25

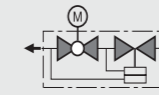

| | |
|----------------------|---|
| Media | Cold and hot water with up to max. 50% glycol |
| Medium temperature | -20...120°C 2...90°C (with actuator) |
| Pipe connection | Internal thread Rp (ISO 7-1) |
| Flow characteristics | A-AB, equal percentage |
| Leakage rate | Leakage rate A, tight (EN 12266-1) |

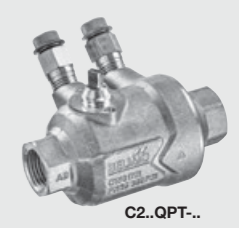
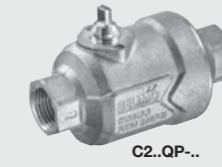

Suitable Actuators

| Nominal torque | Open-close | 3-point | BACnet communication | fail-safe function | Nominal voltage AC/DC 24 V AC 230 V | Running time motor | Actuator type | DN 15 | | DN 20 | | DN 25 | | |
|--|------------|---------|----------------------|--------------------|-------------------------------------|--------------------|---------------|-----------------|--------------------|-----------------------------|--------------------|-----------------------------|--------------------|-----------------------------|
| | | | | | | | | k_{vs} [m³/h] | Valve type | k_{vs} [m³/h] | Valve type | k_{vs} [m³/h] | Valve type | |
| 2.5 | | | | | | | | C315Q-H | 4 | C320Q-J | 4 | C325Q-J | | |
| | | | | | | | | | Δp_s [kPa] | $\Delta p_{max}^{1)}$ [kPa] | Δp_s [kPa] | $\Delta p_{max}^{1)}$ [kPa] | Δp_s [kPa] | $\Delta p_{max}^{1)}$ [kPa] |
| Standard actuators | | | | | | | | | | | | | | |
| 1 Nm | • | • | • | • | 24 V | 75 s | CQ24A | 280 | 280 | 280 | 280 | 280 | 280 | |
| | | | | | | | | CQ24A-BAC | 280 | 280 | 280 | 280 | 280 | 280 |
| | | | | | | | | CQ230A | 280 | 280 | 280 | 280 | 280 | 280 |
| Actuator with fail-safe function NC | | | | | | | | | | | | | | |
| 1 Nm | • | • | • | • | 24 V | 75 s | CQK24A | 280 | 280 | 280 | 280 | 280 | 280 | |
| | | | | | 230 V | 75 s | CQK230A | 280 | 280 | 280 | 280 | 280 | 280 | |
| 2.5 Nm | • | • | • | • | 24 V | 75 s | TQF24 | 280 | 280 | 280 | 280 | 280 | 280 | |
| | | | | | 230 V | 75 s | TQF230 | 280 | 280 | 280 | 280 | 280 | 280 | |
| Fast runners | | | | | | | | | | | | | | |
| 1 Nm | • | • | | | 230 V | 35 s | CQC230A | 280 | 280 | 280 | 280 | 280 | 280 | |

¹⁾ Low noise operation $\Delta p_{max} = 50kPa$

Suitable Actuators

| Nominal torque | Open-close | 3-point | Modulating (2...10 VDC) | MP-Bus® communication | BACnet communication | Fail-safe function | Nominal voltage AC/DC 24 V AC 230 V | Running time motor | Actuator type | DN 15 | | DN 20 | | DN 25 | | |
|--|------------|---------|-------------------------|-----------------------|----------------------|--------------------|-------------------------------------|--------------------|---------------|--------------------|------------------------|--------------------|------------------------|--------------------|------------------------|-----|
| | | | | | | | | | | Δp_s [kPa] | Δp_{max} [kPa] | Δp_s [kPa] | Δp_{max} [kPa] | Δp_s [kPa] | Δp_{max} [kPa] | |
| | | | | | | | | | | V_{nom} [l/s] | Valve type | V_{nom} [l/s] | Valve type | V_{nom} [l/s] | Valve type | |
| 0.058 | • | • | • | • | • | • | 24 V | 75 s | CQ24A | 1400 | 350 | 1400 | 350 | 1400 | 350 | |
| | | | | | | | | | | CQ24A-SR | 1400 | 350 | 1400 | 350 | 1400 | 350 |
| | | | | | | | | | | CQ24A-MPL | 1400 | 350 | 1400 | 350 | 1400 | 350 |
| 0.117 | • | • | • | • | • | • | 24 V | 75 s | CQ24A-BAC | 1400 | 350 | 1400 | 350 | 1400 | 350 | |
| | | | | | | | | | | CQ230A | 1400 | 350 | 1400 | 350 | 1400 | 350 |
| Standard actuators | | | | | | | | | | | | | | | | |
| 1 Nm | • | • | • | • | • | • | 24 V | 75 s | CQK24A | 1400 | 350 | 1400 | 350 | 1400 | 350 | |
| | | | | | | | | | | CQK24A-SR | 1400 | 350 | 1400 | 350 | 1400 | 350 |
| | | | | | | | | | | CQK230A | 1400 | 350 | 1400 | 350 | 1400 | 350 |
| 2.5 Nm | • | • | • | • | • | • | 24 V | 75 s | TQF24 | 1400 | 350 | 1400 | 350 | 1400 | 350 | |
| | | | | | | | | | | TQF230 | 1400 | 350 | 1400 | 350 | 1400 | 350 |
| Actuator with fail-safe function NC | | | | | | | | | | | | | | | | |
| 1 Nm | • | • | • | • | • | • | 24 V | 75 s | CQK24A | 1400 | 350 | 1400 | 350 | 1400 | 350 | |
| | | | | | | | | | | CQK24A-SR | 1400 | 350 | 1400 | 350 | 1400 | 350 |
| 2.5 Nm | • | • | • | • | • | • | 24 V | 75 s | TQF24 | 1400 | 350 | 1400 | 350 | 1400 | 350 | |
| | | | | | | | | | | TQF230 | 1400 | 350 | 1400 | 350 | 1400 | 350 |
| Fast runners | | | | | | | | | | | | | | | | |
| 1 Nm | • | • | | | | | 230 V | 35 s | CQC230A | 1400 | 350 | 1400 | 350 | 1400 | 350 | |

ZoneTight™
Pressure independent flow limiter valve (PIFLV™) /
internal thread / PN 25



DN 15-25

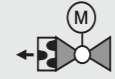

| | |
|--------------------|------------------------------------|
| Media | Cold and hot water |
| Medium temperature | 2...60°C |
| Pipe connection | Internal thread Rp (ISO 7-1) |
| Leakage rate | Leakage rate A, tight (EN 12266-1) |

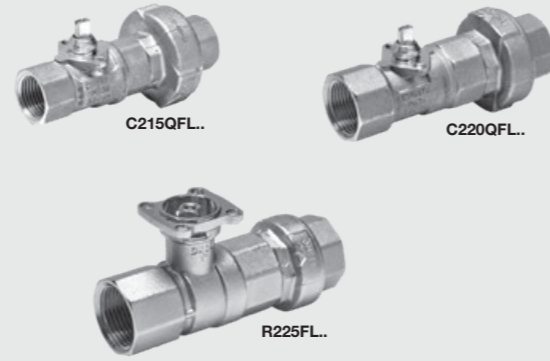

Suitable Actuators

| Actuator type | Nominal torque | Open-close | 3-point | Modulating (2...10 VDC) | MP-Bus® communication | Fail-safe function | Nominal voltage AC/DC 24 V AC 230 V | Running time motor | Valve type | | | |
|---------------|----------------|------------|---------|-------------------------|-----------------------|--------------------|---|--------------------|-------------|-------------|-------|-------|
| | | | | | | | | | DN 15 | DN 20 | DN 25 | DN 25 |
| CQ.. | 1 Nm | • | • | • | • | • | 24 V | 75 s | C215QFL-C | | | |
| | | | | | | | | | C215QFLH-C | | | |
| LR.. | 5 Nm | • | • | • | • | • | 24 V | 90 s | C215QFL-D | | | |
| | | | | | | | | | C215QFLH-D | | | |
| CQK.. | 1 Nm | • | • | • | • | • | 24 V | 75 s | C215QFL-E | | | |
| | | | | | | | | | C215QFLH-E | | | |
| TQF.. | 2.5 Nm | • | • | • | • | • | 24 V | 75 s | C215QFL-F0 | | | |
| | | | | | | | | | C215QFLH-F0 | | | |
| LRF.. | 4 Nm | • | • | • | • | • | 24 V | 75 s | C215QFL-F | C220QFL-F6 | | |
| | | | | | | | | | C215QFLH-F | C220QFLH-F6 | | |
| CQC.. | 1 Nm | • | • | • | • | • | 230 V | 35 s | C220QFL-G0 | | | |
| | | | | | | | | | C220QFLH-G0 | | | |
| LRQ.. | 4 Nm | • | • | • | • | • | 24 V | 9 s | C220QFL-G | | | |
| | | | | | | | | | C220QFLH-G | | | |
| CQC.. | 1 Nm | • | • | • | • | • | 230 V | 35 s | C220QFL-H0 | | | |
| | | | | | | | | | C220QFLH-H0 | | | |
| LRQ.. | 4 Nm | • | • | • | • | • | 24 V | 9 s | C220QFL-H | C225QFLH-H | | |
| | | | | | | | | | C220QFLH-H | C225QFLH-H | | |
| LRQ.. | 4 Nm | • | • | • | • | • | 24 V | 9 s | C225QFLH-J | | | |
| | | | | | | | | | C225QFLH-J | | | |
| LRQ.. | 4 Nm | • | • | • | • | • | 24 V | 9 s | R225FL-J | | | |
| | | | | | | | | | R225FL-J | | | |

| Thermostat type | PIFLV | PIQCV | QCV | Z..S Series |
|--|-------|-------|-----|-------------|
| 3-fan speed control | • | • | • | • |
| 0-10V fan speed control | • | • | • | • |
| Open-close valve control | • | • | • | • |
| DC 0/2-10V valve output | • | • | • | • |
| 4-20mA valve output | • | • | • | • |
| 2-pipe cooling or heating | • | • | • | • |
| 4-pipe cooling or heating | • | • | • | • |
| Occupancy mode | • | • | • | • |
| Nominal voltage AC 24V / AC 220V | • | • | • | • |
| Digital: Built-in or external temperature sensor | | | | |
| EXT-CFU... | • | • | • | • |
| CFU-M... | • | • | • | • |
| Mechanical: Built-in or external temperature sensor | | | | |
| CFU-M... | • | • | • | • |
| CFU-M... | • | • | • | • |

1) Available on request only

2

Electronic pressure-independent characterised control valves

Complete transparency and highest efficiency

| | | | | | |
|--|-----------------|-------|-------|-----------|----|
| Belimo Energy Valve™ | Internal thread | 2-way | PN 25 | DN 15–50 | 12 |
| | Flange | | PN 16 | DN 65–150 | 13 |
| Electronic pressure-independent characterised control valves (EPIV) | Internal thread | 2-way | PN 25 | DN 15–50 | 14 |
| | Flange | | PN 16 | DN 65–150 | 15 |

2

DN 15–50

| | |
|--|--|
| Media | Cold and warm water, water with glycol up to max. 25% vol. |
| Medium temperature | -10...120°C |
| Pipe connection | Internal thread Rp (ISO 7-1) |
| Flow characteristic | Equal percentage (acc. to VDI / VDE 2178) Can be switched to linear |
| Leakage rate | A, air bubble tight (EN 12266-1) |
| V _{max} | Freely adjustable 30... 100% of V _{nom} |
| Completely parameterisable by means of integrated web server | |
| Optional with connection to the Belimo Cloud | |
| Sensor-operated flow rate or power control | |
| Delta-T manager for optimum differential temperature | |

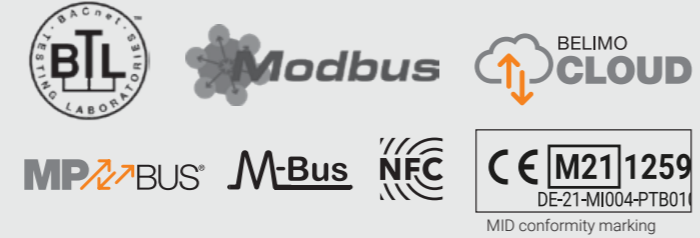
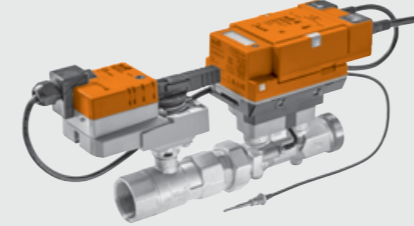
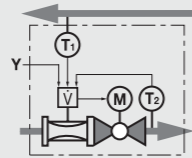

DN 65–150

| | |
|--|--|
| Media | Cold and warm water, water with glycol up to max. 50% vol. |
| Medium temperature | -10...120°C |
| Pipe connection | Flange PN 16 (EN 1092-2) |
| Flow characteristic | Equal percentage (acc. to VDI / VDE 2178) Can be switched to linear |
| Leakage rate | A, air bubble tight (EN 12266-1) |
| V _{max} | Freely adjustable 30... 100% of V _{nom} |
| Completely parameterisable by means of integrated web server | |
| Optional with connection to the Belimo Cloud | |
| Sensor-operated flow rate or power control | |
| Delta-T manager for optimum differential temperature | |

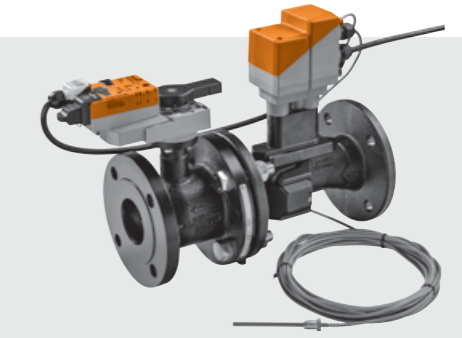
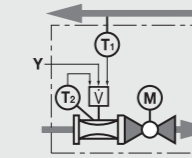

| DN | Rp | V _{nom} | V _{nom} | Nominal voltage AC/DC 24 V | Modulating (2...10 VDC, variable) | MP-Bus® communication | BACnet® communication | Modbus communication | Glycol monitoring 1) | Certified EN1434 / MID | Display | Valve type with actuator | Δp _s [kPa] | Δp _{max} [kPa] |
|--------------------------------|--------|------------------|------------------|----------------------------|-----------------------------------|-----------------------|-----------------------|----------------------|----------------------|------------------------|---------|--------------------------|-----------------------|-------------------------|
| With standard actuator | | | | | | | | | | | | | | |
| 15 | 1/2" | 0.42 l/s | 25 l/min | 24 V | • | • | • | • | • | • | • | EV015R2+MID | 1400 | 350 |
| | | | | | • | • | • | • | • | • | • | EV015R2+BAC | 1400 | 350 |
| 20 | 3/4" | 0.69 l/s | 41.7 l/min | 24 V | • | • | • | • | • | • | • | EV020R2+MID | 1400 | 350 |
| | | | | | • | • | • | • | • | • | • | EV020R2+BAC | 1400 | 350 |
| 25 | 1" | 0.97 l/s | 58.3 l/min | 24 V | • | • | • | • | • | • | • | EV025R2+MID | 1400 | 350 |
| | | | | | • | • | • | • | • | • | • | EV025R2+BAC | 1400 | 350 |
| 32 | 1 1/4" | 1.67 l/s | 100 l/min | 24 V | • | • | • | • | • | • | • | EV032R2+MID | 1400 | 350 |
| | | | | | • | • | • | • | • | • | • | EV032R2+BAC | 1400 | 350 |
| 40 | 1 1/2" | 2.78 l/s | 166.7 l/min | 24 V | • | • | • | • | • | • | • | EV040R2+MID | 1400 | 350 |
| | | | | | • | • | • | • | • | • | • | EV040R2+BAC | 1400 | 350 |
| 50 | 2" | 4.17 l/s | 250 l/min | 24 V | • | • | • | • | • | • | • | EV050R2+MID | 1400 | 350 |
| | | | | | • | • | • | • | • | • | • | EV050R2+BAC | 1400 | 350 |
| | | 6.3 l/s | 378 l/min | 24 V | • | • | • | • | • | • | • | • | EV050R2+BAC-N | 1400 |
| With fail-safe function | | | | | | | | | | | | | | |
| 15 | 1/2" | 0.42 l/s | 25 l/min | 24 V | • | • | • | • | • | • | • | EV015R2+KBAC | 1400 | 350 |
| 20 | 3/4" | 0.69 l/s | 41.7 l/min | 24 V | • | • | • | • | • | • | • | EV020R2+KBAC | 1400 | 350 |
| 25 | 1" | 0.97 l/s | 58.3 l/min | 24 V | • | • | • | • | • | • | • | EV025R2+KBAC | 1400 | 350 |
| 32 | 1 1/4" | 1.67 l/s | 100 l/min | 24 V | • | • | • | • | • | • | • | EV032R2+KBAC | 1400 | 350 |
| 40 | 1 1/2" | 2.78 l/s | 166.7 l/min | 24 V | • | • | • | • | • | • | • | EV040R2+KBAC | 1400 | 350 |
| 50 | 2" | 4.17 l/s | 250 l/min | 24 V | • | • | • | • | • | • | • | EV050R2+KBAC | 1400 | 350 |
| | | 6.3 l/s | 378 l/min | 24 V | • | • | • | • | • | • | • | EV050R2+KBAC-N | 1400 | 350 |

¹⁾ Optimum heat transfer can be ensured with the monitoring of the glycol content.
Remark: Available in Q4 2021.

| DN | V _{nom} | V _{nom} | Nominal voltage AC/DC 24 V | Modulating (2...10 VDC, variable) | MP-Bus® communication | BACnet® communication | Modbus communication | Glycol monitoring 1) | Valve type with actuator | Δp _s [kPa] | Δp _{max} [kPa] |
|--------------------------------|------------------|------------------|----------------------------|-----------------------------------|-----------------------|-----------------------|----------------------|----------------------|--------------------------|-----------------------|-------------------------|
| With standard actuator | | | | | | | | | | | |
| 65 | 8 l/s | 480 l/min | 24 V | • | • | • | • | • | EV065F+BAC | 690 | 340 |
| 80 | 11 l/s | 660 l/min | 24 V | • | • | • | • | • | EV080F+BAC | 690 | 340 |
| 100 | 20 l/s | 1200 l/min | 24 V | • | • | • | • | • | EV100F+BAC | 690 | 340 |
| 125 | 31 l/s | 1860 l/min | 24 V | • | • | • | • | • | EV125F+BAC | 690 | 340 |
| 150 | 45 l/s | 2700 l/min | 24 V | • | • | • | • | • | EV150F+BAC | 690 | 340 |
| With fail-safe function | | | | | | | | | | | |
| 65 | 8 l/s | 480 l/min | 24 V | • | • | • | • | • | EV065F+KBAC | 690 | 340 |
| 80 | 11 l/s | 660 l/min | 24 V | • | • | • | • | • | EV080F+KBAC | 690 | 340 |
| 100 | 20 l/s | 1200 l/min | 24 V | • | • | • | • | • | EV100F+KBAC | 690 | 340 |
| 125 | 31 l/s | 1860 l/min | 24 V | • | • | • | • | • | EV125F+KBAC | 690 | 340 |
| 150 | 45 l/s | 2700 l/min | 24 V | • | • | • | • | • | EV150F+KBAC | 690 | 340 |

¹⁾ Optimum heat transfer can be ensured with the monitoring of the glycol content.
If you have any questions, please get in touch with your local Belimo contact person.

2 Electronic pressure-independent characterised control valves

2 Electronic pressure-independent characterised control valves

Electronic pressure-independent characterised control valve (EPIV)
2-way / PN 25 / internal thread



DN 15–50

| | |
|--|--|
| Media | Cold and warm water, water with glycol up to max. 50% vol. |
| Medium temperature | -10...120°C |
| Pipe connection | Internal thread Rp (ISO 7-1) |
| Flow characteristic | Equal percentage (acc. to VDI / VDE 2178) Can be switched to linear |
| Leakage rate | A, air bubble tight (EN 12266-1) |
| V _{max} | Freely adjustable 25... 100% of V _{nom} |
| Control, operating range, position feedback and further functions are parameterisable with PC-Tool, NFC/Apps | |

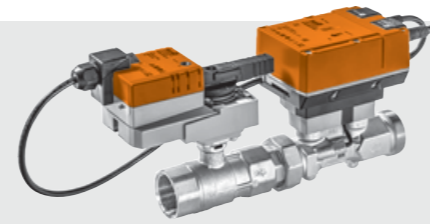
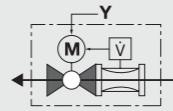

| DN | Rp | V _{nom} | V _{nom} | Nominal voltage AC/DC 24 V | Modulating (2...10 VDC, variable) | MP-Bus® communication | Modbus communication | BACnet® communication | Valve type with actuator | Δp _s [kPa] | Δp _{max} [kPa] |
|--------------------------------------|--------|------------------|------------------|----------------------------|-----------------------------------|-----------------------|----------------------|-----------------------|--------------------------|-----------------------|-------------------------|
| With BACnet / Modbus actuator | | | | | | | | | | | |
| 15 | 1/2" | 0.42 l/s | 25 l/min | 24 V | • | • | • | • | EP015R2+BAC | 1400 | 350 |
| 20 | 3/4" | 0.69 l/s | 41.7 l/min | 24 V | • | • | • | • | EP020R2+BAC | 1400 | 350 |
| 25 | 1" | 0.97 l/s | 58.3 l/min | 24 V | • | • | • | • | EP025R2+BAC | 1400 | 350 |
| 32 | 1 1/4" | 1.67 l/s | 100 l/min | 24 V | • | • | • | • | EP032R2+BAC | 1400 | 350 |
| 40 | 1 1/2" | 2.78 l/s | 166.7 l/min | 24 V | • | • | • | • | EP040R2+BAC | 1400 | 350 |
| 50 | 2" | 4.17 l/s | 250 l/min | 24 V | • | • | • | • | EP050R2+BAC | 1400 | 350 |
| | | 6.3 l/s | 378 l/min | 24 V | • | • | • | • | EP050R2+BAC-N | 1400 | 350 |
| With fail-safe function | | | | | | | | | | | |
| 15 | 1/2" | 0.42 l/s | 25 l/min | 24 V | • | • | • | • | EP015R2+KBAC | 1400 | 350 |
| 20 | 3/4" | 0.69 l/s | 41.7 l/min | 24 V | • | • | • | • | EP020R2+KBAC | 1400 | 350 |
| 25 | 1" | 0.97 l/s | 58.3 l/min | 24 V | • | • | • | • | EP025R2+KBAC | 1400 | 350 |
| 32 | 1 1/4" | 1.67 l/s | 100 l/min | 24 V | • | • | • | • | EP032R2+KBAC | 1400 | 350 |
| 40 | 1 1/2" | 2.78 l/s | 166.7 l/min | 24 V | • | • | • | • | EP040R2+KBAC | 1400 | 350 |
| 50 | 2" | 4.17 l/s | 250 l/min | 24 V | • | • | • | • | EP050R2+KBAC | 1400 | 350 |
| | | 6.3 l/s | 378 l/min | 24 V | • | • | • | • | EP050R2+KBAC-N | 1400 | 350 |

Remark: Available in Q4 2021.



Electronic pressure-independent characterised control valve (EPIV)
2-way / PN 16 / flange

DN 65–150

| | |
|--|--|
| Media | Cold and warm water, water with glycol up to max. 50% vol. |
| Medium temperature | -10...120°C |
| Pipe connection | Flange PN 16 (EN 1092-2) |
| Flow characteristic | Equal percentage (acc. to VDI / VDE 2178) Can be switched to linear |
| Leakage rate | A, air bubble tight (EN 12266-1) |
| V _{max} | Freely adjustable 30... 100% of V _{nom} |
| Control, operating range, position feedback and further functions are parameterisable with PC-Tool | |

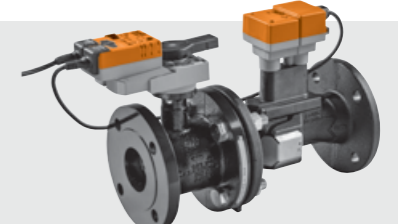
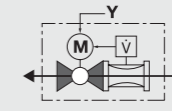

| DN | V _{nom} | V _{nom} | Nominal voltage AC/DC 24 V | Modulating (2...10 VDC, variable) | MP-Bus® communication | Modbus communication | BACnet® communication | Valve type with actuator | Δp _s [kPa] | Δp _{max} [kPa] |
|--------------------------------------|------------------|------------------|----------------------------|-----------------------------------|-----------------------|----------------------|-----------------------|--------------------------|-----------------------|-------------------------|
| With standard actuator | | | | | | | | | | |
| 65 | 8 l/s | 480 l/min | 24 V | • | • | • | • | EP065F+MP | 690 | 340 |
| 80 | 11 l/s | 660 l/min | 24 V | • | • | • | • | EP080F+MP | 690 | 340 |
| 100 | 20 l/s | 1200 l/min | 24 V | • | • | • | • | EP100F+MP | 690 | 340 |
| 125 | 31 l/s | 1860 l/min | 24 V | • | • | • | • | EP125F+MP | 690 | 340 |
| 150 | 45 l/s | 2700 l/min | 24 V | • | • | • | • | EP150F+MP | 690 | 340 |
| With fail-safe function | | | | | | | | | | |
| 65 | 8 l/s | 480 l/min | 24 V | • | • | • | • | EP065F+KMP | 690 | 340 |
| 80 | 11 l/s | 660 l/min | 24 V | • | • | • | • | EP080F+KMP | 690 | 340 |
| 100 | 20 l/s | 1200 l/min | 24 V | • | • | • | • | EP100F+KMP | 690 | 340 |
| 125 | 31 l/s | 1860 l/min | 24 V | • | • | • | • | EP125F+KMP | 690 | 340 |
| 150 | 45 l/s | 2700 l/min | 24 V | • | • | • | • | EP150F+KMP | 690 | 340 |
| With BACnet / Modbus actuator | | | | | | | | | | |
| 65 | 8 l/s | 480 l/min | 24 V | • | • | • | • | EP065F+MOD | 690 | 340 |
| 80 | 11 l/s | 660 l/min | 24 V | • | • | • | • | EP080F+MOD | 690 | 340 |
| 100 | 20 l/s | 1200 l/min | 24 V | • | • | • | • | EP100F+MOD | 690 | 340 |
| 125 | 31 l/s | 1860 l/min | 24 V | • | • | • | • | EP125F+MOD | 690 | 340 |
| 150 | 45 l/s | 2700 l/min | 24 V | • | • | • | • | EP150F+MOD | 690 | 340 |

If you have any questions, please get in touch with your local Belimo contact person.

3

Characterised control valves (CCV)

Reliable control of
heating and cooling circuits

| | | | | | |
|--|-----------------|-------|---------|-----------|----|
| Characterised Control Valve | Internal thread | 2-way | PN 25 / | DN 15–80 | 18 |
| | | 3-way | PN 40 | | 18 |
| | Flange | 2-way | PN 16 | DN 65–150 | 20 |

DN 15-80



| | |
|---------------------|--|
| Media | Cold and hot water with up to max. 50% glycol |
| Medium temperature | -10...120°C (DN 15...50) (small actuators TR... only up to 100°C) |
| Pipe connection | Internal thread Rp (ISO 7-1) |
| Flow characteristic | A-AB equal percentage / B-AB linear (k_{vs} 70% of A-AB) |
| Leakage rate | Control path A-AB: Leakage rate A, air bubble tight (EN 12266-1) Bypass B-AB: Leakage class I |



Closed and open water circuit

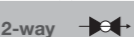

| DN 15 | | DN 20 | |
|-----------------|--------------|-----------------|--------------|
| k_{vs} [m³/h] | Valve type | k_{vs} [m³/h] | Valve type |
| 0.25 | R2015-P25-S1 | 4 | R2020-4-S2 |
| 0.4 | R2015-P4-S1 | 6.3 | R2020-6P3-S2 |
| 0.63 | R2015-P63-S1 | 8.6 | R2020-8P6-S2 |
| 1 | R2015-1-S1 | | |
| 1.6 | R2015-1P6-S1 | | |
| 2.5 | R2015-2P5-S1 | | |
| 4 | R2015-4-S1 | | |
| 6.3 | R2015-6P3-S1 | | |



Closed water circuit

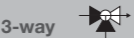

| DN 15 | | DN 20 | |
|-----------------|--------------|-----------------|--------------|
| k_{vs} [m³/h] | Valve type | k_{vs} [m³/h] | Valve type |
| 0.25 | R3015-P25-S1 | 4 | R3020-4-S2 |
| 0.4 | R3015-P4-S1 | 6.3 | R3020-6P3-S2 |
| 0.63 | R3015-P63-S1 | 8.6 | R3020-8P6-S2 |
| 1 | R3015-1-S1 | | |
| 1.6 | R3015-1P6-S1 | | |
| 2.5 | R3015-2P5-S1 | | |
| 4 | R3015-4-S1 | | |
| 6.3 | R3015-6P3-S1 | | |

Suitable Actuators

| Nominal torque | Open-close | 3-point | Modulating (2...10 VDC) | Modulating (0.5...10 VDC) | Fail-safe function | Nominal voltage | Running time motor 90° | Running time emergency control function |
|----------------|------------|---------|-------------------------|---------------------------|--------------------|-----------------|------------------------|---|
| 2 Nm | • | • | | | | 24 V | 100 s | |
| 5 Nm | • | • | | | | 24 V | 90 s | |
| 10 Nm | • | • | | | | 24 V | 90 s | |
| 20 Nm | • | • | | | | 24 V | 90 s | |

Small and compact actuators

| Actuator type | Δp_s [kPa] | $\Delta p_{max}^{(1)}$ [kPa] | Δp_s [kPa] | $\Delta p_{max}^{(1)}$ [kPa] | Δp_s [kPa] | $\Delta p_{max}^{(1)}$ [kPa] |
|---------------|--------------------|------------------------------|--------------------|------------------------------|--------------------|------------------------------|
| | | | | | | |
| 2 Nm | 1400 | 350 | 1400 | 350 | | |
| 5 Nm | 1400 | 350 | 1400 | 350 | | |
| 10 Nm | 1400 | 350 | 1400 | 350 | | |

Standard actuators

| Actuator type | Δp_s [kPa] | $\Delta p_{max}^{(1)}$ [kPa] | Δp_s [kPa] | $\Delta p_{max}^{(1)}$ [kPa] | Δp_s [kPa] | $\Delta p_{max}^{(1)}$ [kPa] | | | | | |
|---------------|--------------------|------------------------------|--------------------|------------------------------|--------------------|------------------------------|-------|--------|----------|----------|-------|
| | | | | | | | LR24A | LR230A | LR24A-SR | LR24A-SZ | NR24A |
| 5 Nm | 1400 | 350 | 1400 | 350 | | | | | | | |
| 10 Nm | 1400 | 350 | 1400 | 350 | | | | | | | |
| 20 Nm | 1400 | 350 | 1400 | 350 | | | | | | | |

Fast running actuators

| Actuator type | Δp_s [kPa] | $\Delta p_{max}^{(1)}$ [kPa] | Δp_s [kPa] | $\Delta p_{max}^{(1)}$ [kPa] | Δp_s [kPa] | $\Delta p_{max}^{(1)}$ [kPa] |
|---------------|--------------------|------------------------------|--------------------|------------------------------|--------------------|------------------------------|
| | | | | | | |
| 4 Nm | 1400 | 350 | 1400 | 350 | 1400 | 350 |
| 8 Nm | 1400 | 350 | 1400 | 350 | 1400 | 350 |
| 16 Nm | 1400 | 350 | 1400 | 350 | 1400 | 350 |

Actuators with fail-safe function

| Actuator type | Δp_s [kPa] | $\Delta p_{max}^{(1)}$ [kPa] | Δp_s [kPa] | $\Delta p_{max}^{(1)}$ [kPa] | Δp_s [kPa] | $\Delta p_{max}^{(1)}$ [kPa] | | | | | | | |
|---------------|--------------------|------------------------------|--------------------|------------------------------|--------------------|------------------------------|-------|--------|----------|----------|----------|----------|------|
| | | | | | | | TRF24 | TRF230 | TRF24-SR | TRF24-SR | TRF24-SR | TRF24-SR | NRFA |
| 2.5 Nm | 1400 | 350 | 1400 | 350 | | | | | | | | | |
| 4 Nm | 1400 | 350 | 1400 | 350 | | | | | | | | | |
| 10 Nm | 1400 | 350 | 1400 | 350 | | | | | | | | | |
| 20 Nm | 1400 | 350 | 1400 | 350 | | | | | | | | | |

Legend Recommended model
 Optional model

¹ Low-noise operation $\Delta p_{max} = 200$ kPa.
² If medium temperature $\geq 100^\circ\text{C}$, then the line and the valve must be insulated.
³ Non-spring: using NR...series actuator for application $>70^\circ\text{C}$.
 Fast-running: using NRQ...series actuator for application $>70^\circ\text{C}$.
 Spring return: using NRF...series actuator for application $>70^\circ\text{C}$.

| DN 25 | | DN 32 | | DN 40 | | DN 50 | |
|-----------------|--------------|-----------------|-------------|-----------------|-------------|-----------------|-------------|
| k_{vs} [m³/h] | Valve type | k_{vs} [m³/h] | Valve type | k_{vs} [m³/h] | Valve type | k_{vs} [m³/h] | Valve type |
| 6.3 | R2025-6P3-S2 | 10 | R2032-10-S2 | 16 | R2040-16-S2 | 25 | R2050-25-S4 |
| 10 | R2025-10-S2 | 16 | R2032-16-S3 | 25 | R2040-25-S2 | 40 | R2050-40-S4 |
| 16 | R2025-16-S2 | 25 | R2032-25-S3 | 40 | R2040-40-S4 | 58 | R2050-58-S4 |
| 25 | R2025-25-S2 | | | | | | |

| DN 25 | | DN 32 | | DN 40 | | DN 50 | |
|-----------------|--------------|-----------------|-------------|-----------------|-------------|-----------------|-------------|
| k_{vs} [m³/h] | Valve type | k_{vs} [m³/h] | Valve type | k_{vs} [m³/h] | Valve type | k_{vs} [m³/h] | Valve type |
| 6.3 | R3025-6P3-S2 | 10 | R3032-10-S2 | 16 | R3040-16-S3 | 25 | R3050-25-S4 |
| 10 | R3025-10-S2 | 16 | R3032-16-S3 | 25 | R3040-25-S4 | 40 | R3050-40-S4 |
| | | | | | | | |

| Actuator type | Δp_s [kPa] | $\Delta p_{max}^{(1)}$ [kPa] | Δp_s [kPa] | $\Delta p_{max}^{(1)}$ [kPa] | Δp_s [kPa] | $\Delta p_{max}^{(1)}$ [kPa] | Δp_s [kPa] | $\Delta p_{max}^{(1)}$ [kPa] |
|---------------|--------------------|------------------------------|--------------------|------------------------------|--------------------|------------------------------|--------------------|------------------------------|
| | | | | | | | | |
| 2 Nm | 1400 | 350 | 1400 | 350 | 1400 | 350 | | |
| 5 Nm | 1400 | 350 | 1400 | 350 | 1400 | 350 | | |
| 10 Nm | 1400 | 350 | 1400 | 350 | 1400 | 350 | | |
| 20 Nm | 1400 | 350 | 1400 | 350 | 1400 | 350 | | |

| Actuator type | Δp_s [kPa] | $\Delta p_{max}^{(1)}$ [kPa] | Δp_s [kPa] | $\Delta p_{max}^{(1)}$ [kPa] | Δp_s [kPa] | $\Delta p_{max}^{(1)}$ [kPa] | Δp_s [kPa] | $\Delta p_{max}^{(1)}$ [kPa] |
|---------------|--------------------|------------------------------|--------------------|------------------------------|--------------------|------------------------------|--------------------|------------------------------|
| | | | | | | | | |
| 2 Nm | 1400 | 350 | 1400 | 350 | 1400 | 350 | | |
| 5 Nm | 1400 | 350 | 1400 | 350 | 1400 | 350 | | |
| 10 Nm | 1400 | 350 | 1400 | 350 | 1400 | 350 | | |
| 20 Nm | 1400 | 350 | 1400 | 350 | 1400 | 350 | | |

| Actuator type | Δp_s [kPa] | $\Delta p_{max}^{(1)}$ [kPa] | Δp_s [kPa] | $\Delta p_{max}^{(1)}$ [kPa] | Δp_s [kPa] | $\Delta p_{max}^{(1)}$ [kPa] | Δp_s [kPa] | $\Delta p_{max}^{(1)}$ [kPa] |
|---------------|--------------------|------------------------------|--------------------|------------------------------|--------------------|------------------------------|--------------------|------------------------------|
| | | | | | | | | |
| 2 Nm | 1400 | 350 | 1400 | 350 | 1400 | 350 | | |
| 5 Nm | 1400 | 350 | 1400 | 350 | 1400 | 350 | | |
| 10 Nm | 1400 | 350 | 1400 | 350 | 1400 | 350 | | |
| 20 Nm | 1400 | 350 | 1400 | 350 | 1400 | 350 | | |

| Actuator type | Δp_s [kPa] | $\Delta p_{max}^{(1)}$ [kPa] | Δp_s [kPa] | $\Delta p_{max}^{(1)}$ [kPa] | Δp_s [kPa] | $\Delta p_{max}^{(1)}$ [kPa] | Δp_s [kPa] | $\Delta p_{max}^{(1)}$ [kPa] |
|---------------|--------------------|------------------------------|--------------------|------------------------------|--------------------|------------------------------|--------------------|------------------------------|
| | | | | | | | | |
| 2 Nm | 1400 | 350 | 1400 | 350 | 1400 | 350 | | |
| 5 Nm | 1400 | 350 | 1400 | 350 | 1400 | 350 | | |
| 10 Nm | 1400 | 350 | 1400 | 350 | 1400 | 350 | | |
| 20 Nm | 1400 | 350 | 1400 | 350 | 1400 | 350 | | |

| Actuator type | Δp_s [kPa] | $\Delta p_{max}^{(1)}$ [kPa] | Δp_s [kPa] | $\Delta p_{max}^{(1)}$ [kPa] | Δp_s [kPa] | $\Delta p_{max}^{(1)}$ [kPa] | Δp_s [kPa] | $\Delta p_{max}^{(1)}$ [kPa] |
|---------------|--------------------|------------------------------|--------------------|------------------------------|--------------------|------------------------------|--------------------|------------------------------|
| | | | | | | | | |
| 2 Nm | 1400 | 350 | 1400 | 350 | 1400 | 350 | | |
| 5 Nm | 1400 | 350 | 1400 | 350 | 1400 | 350 | | |
| 10 Nm | 1400 | 350 | 1400 | 350 | 1400 | 350 | | |
| 20 Nm | 1400 | 350 | 1400 | 350 | 1400 | 350 | | |

DN 65 – 150



| | |
|---------------------|---|
| Media | Cold and hot water with up to max. 50% glycol |
| Medium temperature | -5...100°C |
| Pipe connection | Flange PN 16 |
| Flow characteristic | A-AB, equal percentage |
| Leakage rate | Leakage rate A, tight (EN 12266-1) |

Suitable Actuators

| Nominal torque | Open-close | 3-point | Modulating (2...10 VDC) | Modulating (0.5...10 VDC) | Fail-safe function | Nominal voltage | Running time motor 90° | Running time emergency control function | Auxiliary switch SPDT |
|----------------|------------|---------|-------------------------|---------------------------|--------------------|-----------------|------------------------|---|-----------------------|
| 20 Nm | • | • | • | • | • | 24 V | 90 s | | |
| 40 Nm | • | • | • | • | • | 24 V | 150 s | | |



Closed water circuit

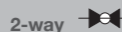

| DN 65 | | DN 80 | |
|-----------------|------------|-----------------|------------|
| k_{vs} [m³/h] | Valve type | k_{vs} [m³/h] | Valve type |
| 63 | R664AO | 100 | R679AO |

| Standard actuators | | Actuator type | Δp_s [kPa] | $\Delta p_{max}^{1)}$ [kPa] | Δp_s [kPa] | $\Delta p_{max}^{1)}$ [kPa] |
|---|-----------|---------------|--------------------|-----------------------------|--------------------|-----------------------------|
| 20 Nm | SR.. | SR24A-5 | 700 | 350 | 700 | 350 |
| | | SR230A-5 | 700 | 350 | 700 | 350 |
| | | SR24A-SR-5 | 700 | 350 | 700 | 350 |
| | | SR230A-SR-5 | 700 | 350 | 700 | 350 |
| 40 Nm | GR.. | GR24A-7 | | | | |
| | | GR230A-7 | | | | |
| | | GR24A-SR-7 | | | | |
| Fast running actuators | | Actuator type | Δp_s [kPa] | $\Delta p_{max}^{1)}$ [kPa] | Δp_s [kPa] | $\Delta p_{max}^{1)}$ [kPa] |
| 16 Nm | SRQ..AX.. | SRQ..AX..-5* | 700 | 350 | | |
| Actuators with fail-safe function NC / NO | | Actuator type | Δp_s [kPa] | $\Delta p_{max}^{1)}$ [kPa] | Δp_s [kPa] | $\Delta p_{max}^{1)}$ [kPa] |
| 20 Nm | SRF.. | SRFA-5 | 700 | 350 | 700 | 350 |
| | | SRFA-S2-5 | 700 | 350 | 700 | 350 |
| | | SRF24A-SR-5 | 700 | 350 | 700 | 350 |
| | | GRK24A-7 | | | | |
| 40 Nm | GRK.. | GRK24A-MF-7 | | | | |

* Only available via VC
1) Low-noise operation $\Delta p_{max} = 200$ kPa.

| DN 100 | | DN 125 | | DN 150 | |
|-----------------|------------|-----------------|------------|-----------------|------------|
| k_{vs} [m³/h] | Valve type | k_{vs} [m³/h] | Valve type | k_{vs} [m³/h] | Valve type |
| 140 | R6099AO | 230 | R6124AO | 320 | R6149AO |

| Δp_s [kPa] | $\Delta p_{max}^{1)}$ [kPa] | Δp_s [kPa] | $\Delta p_{max}^{1)}$ [kPa] | Δp_s [kPa] | $\Delta p_{max}^{1)}$ [kPa] |
|--------------------|-----------------------------|--------------------|-----------------------------|--------------------|-----------------------------|
| | | | | | |
| 700 | 350 | 700 | 350 | 400 | 250 |
| 700 | 350 | 700 | 350 | 400 | 250 |
| 700 | 350 | 700 | 350 | 400 | 250 |

| Δp_s [kPa] | $\Delta p_{max}^{1)}$ [kPa] | Δp_s [kPa] | $\Delta p_{max}^{1)}$ [kPa] | Δp_s [kPa] | $\Delta p_{max}^{1)}$ [kPa] |
|--------------------|-----------------------------|--------------------|-----------------------------|--------------------|-----------------------------|
| | | | | | |
| 700 | 350 | 700 | 350 | 400 | 250 |
| 700 | 350 | 700 | 350 | 400 | 250 |

Continued next page

Continued from previous page

4

Globe valves

Energy-optimised control of steam, cold water, low temperature hot water and high temperature water circuits

| | | | | |
|-----------------|-----------------------|---|-------------------|----|
| Internal thread | <u>2-way</u> 3-way | Stainless steel for cold and hot water applications | PN 25 / DN 15–50 | 24 |
| Flange | <u>2-way</u> 3-way | Ductile iron for cold and hot water applications | PN 16 / DN 65–250 | 26 |
| Flange | 2-way | Ductile iron for cold, hot and steam applications | PN 25 / DN 15–250 | 28 |

DN 15-50



| | |
|---------------------|---|
| Media | Cold, warm and hot water, water with glycol up to max. 50% vol. |
| Medium temperature | 0...130°C |
| Pipe connection | Internal thread (ISO 7-1) |
| Flow characteristic | A-AB equal percentage / B-AB linear |
| Leakage rate | Control path and bypass 0.02% of k_{VS} value |



Closed cold and hot water systems

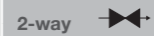

Closed cold and hot water systems



| DN 15 | | DN 15 | |
|-----------------|------------|-----------------|------------|
| k_{VS} [m³/h] | Valve type | k_{VS} [m³/h] | Valve type |
| 1.6 | H215S-G | 4.0 | H215S-J |
| 1.6 | H315S-G | 4.0 | H315S-J |

Suitable Actuators

- Actuating force
- Actuating time per nominal stroke
- Actuating time for emergency control function
- Open-close
- 3-point
- Modulating (0.5...10 VDC)
- Modulating (2...10 VDC)
- MP-Bus® communication
- fail-safe function
- Nominal voltage AC/DC 24 V AC 230 V

Standard actuators

| Actuator type | Voltage | Actuator type | Δp_s [kPa] | | | Δp_{max} [kPa] | | |
|---------------|---------|---------------|--------------------|--------------------|-----------------------|------------------------|--------------------|-----------------------|
| | | | 2-way 3-way Mixing | 2-way 3-way Mixing | 3-way 3-way Diverting | 2-way 3-way Mixing | 2-way 3-way Mixing | 3-way 3-way Diverting |
| 1000 N 150 s | 24 V | NV24A-TPC | 800 | 800 | 400 | 800 | 800 | 400 |
| | 230 V | NV230A-TPC | 800 | 800 | 400 | 800 | 800 | 400 |
| | 24 V | NV24A-SZ-TPC | 800 | 800 | 400 | 800 | 800 | 400 |
| | 24 V | NV24A-MP-TPC | 800 | 800 | 400 | 800 | 800 | 400 |
| 1500 N 150 s | 24 V | SV24A-TPC | | | | | | |
| | 230 V | SV230A-TPC | | | | | | |
| | 24 V | SV24A-SZ-TPC | | | | | | |
| | 24 V | SV24A-MP-TPC | | | | | | |

Actuators with fail-safe function NC / NO

| Actuator type | Voltage | Actuator type | Δp_s [kPa] | | | Δp_{max} [kPa] | | |
|-------------------|---------|----------------|--------------------|--------------------|-----------------------|------------------------|--------------------|-----------------------|
| | | | 2-way 3-way Mixing | 2-way 3-way Mixing | 3-way 3-way Diverting | 2-way 3-way Mixing | 2-way 3-way Mixing | 3-way 3-way Diverting |
| 1000 N 150 s 35 s | 24 V | NVK24A-3-TPC | 800 | 800 | 400 | 800 | 800 | 400 |
| | 230 V | NVK230A-3 | 800 | 800 | 400 | 800 | 800 | 400 |
| 1500 N 150 s 35 s | 24 V | NVK24A-MP-TPC | 800 | 800 | 400 | 800 | 800 | 400 |
| | 24 V | SVK24A-3-TPC* | | | | | | |
| | 230 V | SVK230-3* | | | | | | |
| | 24 V | SVK24A-MP-TPC* | | | | | | |

* Only available through VC.

| DN 20 | | DN 25 | | DN 32 | | DN 40 | | DN 50 | |
|-----------------|------------|-----------------|------------|-----------------|------------|-----------------|------------|-----------------|------------|
| k_{VS} [m³/h] | Valve type | k_{VS} [m³/h] | Valve type | k_{VS} [m³/h] | Valve type | k_{VS} [m³/h] | Valve type | k_{VS} [m³/h] | Valve type |
| 6.3 | H220S-K | 10 | H225S-L | 16 | H232S-M | 25 | H240S-N | 40 | H250S-P |
| 6.3 | H320S-K | 10 | H325S-L | 16 | H332S-M | 25 | H340S-N | 40 | H350S-P |

| Actuator type | Voltage | Actuator type | Δp_s [kPa] | | | Δp_{max} [kPa] | | |
|---------------|---------|---------------|--------------------|--------------------|-----------------------|------------------------|--------------------|-----------------------|
| | | | 2-way 3-way Mixing | 2-way 3-way Mixing | 3-way 3-way Diverting | 2-way 3-way Mixing | 2-way 3-way Mixing | 3-way 3-way Diverting |
| 1000 N 150 s | 24 V | H220S-K | 800 | 800 | 400 | 600 | 600 | 300 |
| | 230 V | H225S-L | 800 | 800 | 400 | 600 | 600 | 300 |
| | 24 V | H232S-M | 800 | 800 | 400 | 600 | 600 | 300 |
| | 24 V | H240S-N | 800 | 800 | 400 | 600 | 600 | 300 |
| 1500 N 150 s | 24 V | H320S-K | | | | 700 | 700 | 350 |
| | 230 V | H325S-L | | | | 700 | 700 | 350 |
| | 24 V | H332S-M | | | | 700 | 700 | 350 |
| | 24 V | H340S-N | | | | 700 | 700 | 350 |

| Actuator type | Voltage | Actuator type | Δp_s [kPa] | | | Δp_{max} [kPa] | | |
|-------------------|---------|---------------|--------------------|--------------------|-----------------------|------------------------|--------------------|-----------------------|
| | | | 2-way 3-way Mixing | 2-way 3-way Mixing | 3-way 3-way Diverting | 2-way 3-way Mixing | 2-way 3-way Mixing | 3-way 3-way Diverting |
| 1000 N 150 s 35 s | 24 V | H220S-K | 800 | 800 | 400 | 600 | 600 | 300 |
| | 230 V | H225S-L | 800 | 800 | 400 | 600 | 600 | 300 |
| 1500 N 150 s 35 s | 24 V | H320S-K | | | | 700 | 700 | 350 |
| | 230 V | H325S-L | | | | 700 | 700 | 350 |
| | 24 V | H332S-M | | | | 700 | 700 | 350 |
| | 24 V | H340S-N | | | | 700 | 700 | 350 |

DN 65 – 250



| | |
|---------------------|---|
| Media | Cold, warm and hot water, water with glycol up to max. 50% vol. |
| Medium temperature | 0...150°C |
| Pipe connection | Flange PN 16 (ISO 7005-2) |
| Flow characteristic | A-AB equal percentage / B-AB linear |
| Leakage rate | Max. 0.02% of k_{vs} value |



Closed cold and hot water systems

2-way

| k_{vs} [m³/h] | Valve type |
|-----------------|------------|
| 63 | H665SP-Q |



Closed cold and hot water systems

3-way

| k_{vs} [m³/h] | Valve type |
|-----------------|------------|
| 63 | H765D-Q |
| | H765S-Q |

Suitable Actuators

- Actuating force
- Actuating time per nominal stroke
- Actuating time for emergency control function
- Open-close
- 3-point
- Modulating (0.5...10 VDC)
- Modulating (2...10 VDC)
- MP-Bus® communication
- Fail-safe function
- Nominal voltage AC/DC 24 V AC 230 V

Standard actuators

| Actuator type | Δp_s 2-way [kPa] | Δp_{max} 2-way [kPa] | $\Delta p_s / \Delta p_{max}$ 3-way Mixing [kPa] | $\Delta p_s / \Delta p_{max}$ 3-way Diverting [kPa] | Nominal voltage | Actuator type | |
|---------------|--------------------------|------------------------------|--|---|-----------------|---------------|-----------------|
| | | | | | | Actuator type | Nominal voltage |
| 1500 N 150 s | • | • | • | • | 24 V | SV24A-TPC | 230 V |
| | | | | | | SV230A-TPC | 24 V |
| | | | | | | SV24A-SZ-TPC | 24 V |
| | | | | | | SV24A-MP-TPC | 24 V |
| 2500 N 150 s | • | • | • | • | 24 V | EV24A-TPC | 230 V |
| | | | | | | EV230A-TPC | 24 V |
| | | | | | | EV24A-SZ-TPC | 24 V |
| | | | | | | EV24A-MP-TPC | 24 V |
| 4500 N 150 s | • | • | • | • | 24 V | RV24A-SZ | 24 V |
| | | | | | | RV24A-MF | 24 V |

Actuators with fail-safe function NC / NO

| Actuator type | Δp_s 2-way [kPa] | Δp_{max} 2-way [kPa] | $\Delta p_s / \Delta p_{max}$ 3-way Mixing [kPa] | $\Delta p_s / \Delta p_{max}$ 3-way Diverting [kPa] | Nominal voltage | Actuator type | |
|-------------------|--------------------------|------------------------------|--|---|-----------------|----------------|-----------------|
| | | | | | | Actuator type | Nominal voltage |
| 1500 N 150 s 35 s | • | • | • | • | 24 V | SVK24A-3-TPC* | 230 V |
| | | | | | | SVK230-3* | 24 V |
| | | | | | | SVK24A-MP-TPC* | 24 V |
| 2000 N 150 s 35 s | • | • | • | • | 24 V | AVK24AX-3* | 230 V |
| | | | | | | AVK230A-3 | 24 V |
| | | | | | | AVK24A-MP-TPC | 24 V |
| 2500 N 150 s 35 s | • | • | • | • | 24 V | EVK24A-3-TPC | 230 V |
| | | | | | | EVK230A-3 | 24 V |
| | | | | | | EVK24A-MP-TPC | 24 V |

* Only available through VC.

| DN 80 | DN 100 | DN 125 | DN 150 | DN 200 | DN 250 |
|----------------------------|----------------------------|----------------------------|----------------------------|----------------------------|----------------------------|
| k_{vs} [m³/h] Valve type | k_{vs} [m³/h] Valve type | k_{vs} [m³/h] Valve type | k_{vs} [m³/h] Valve type | k_{vs} [m³/h] Valve type | k_{vs} [m³/h] Valve type |
| 100 H680SP-R | 160 H6100SP-S | 250 H6125SP-T | 350 H6150SP-T | 520 H6200SP-U | 700 H6250SP-V |
| k_{vs} [m³/h] Valve type | k_{vs} [m³/h] Valve type | k_{vs} [m³/h] Valve type | k_{vs} [m³/h] Valve type | k_{vs} [m³/h] Valve type | k_{vs} [m³/h] Valve type |
| 100 H780D-R H780S-R | 160 H7100D-S H7100S-S | 250 H7125D-T H7125S-T | 350 H7150D-T H7150S-T | 520 H7200D-U H7200S-U | 700 H7250S-V |

| Δp_s 2-way [kPa] | Δp_{max} 2-way [kPa] | $\Delta p_s / \Delta p_{max}$ 3-way [kPa] | Δp_s 2-way [kPa] | Δp_{max} 2-way [kPa] | $\Delta p_s / \Delta p_{max}$ 3-way [kPa] | Δp_s 2-way [kPa] | Δp_{max} 2-way [kPa] | $\Delta p_s / \Delta p_{max}$ 3-way [kPa] | Δp_s 2-way [kPa] | Δp_{max} 2-way [kPa] | $\Delta p_s / \Delta p_{max}$ 3-way [kPa] | Δp_s 2-way [kPa] | Δp_{max} 2-way [kPa] | $\Delta p_s / \Delta p_{max}$ 3-way [kPa] | Δp_s 2-way [kPa] | Δp_{max} 2-way [kPa] | $\Delta p_s / \Delta p_{max}$ 3-way [kPa] | Δp_s 2-way [kPa] | Δp_{max} 2-way [kPa] | $\Delta p_s / \Delta p_{max}$ 3-way [kPa] |
|--------------------------|------------------------------|---|--------------------------|------------------------------|---|--------------------------|------------------------------|---|--------------------------|------------------------------|---|--------------------------|------------------------------|---|--------------------------|------------------------------|---|--------------------------|------------------------------|---|
| 1600 | 1000 | 200 | 1600 | 1000 | 200 | 1600 | 1000 | 110 | 1600 | 1000 | 60 | 1600 | 1000 | | | | | | | |
| 1600 | 1000 | 200 | 1600 | 1000 | 200 | 1600 | 1000 | 110 | 1600 | 1000 | 60 | 1600 | 1000 | | | | | | | |
| 1600 | 1000 | 200 | 1600 | 1000 | 200 | 1600 | 1000 | 110 | 1600 | 1000 | 60 | 1600 | 1000 | | | | | | | |
| 1600 | 1000 | 200 | 1600 | 1000 | 200 | 1600 | 1000 | 110 | 1600 | 1000 | 60 | 1600 | 1000 | | | | | | | |
| 1600 | 1000 | 200 | 1600 | 1000 | 200 | 1600 | 1000 | 150 | 1600 | 1000 | 100 | 1600 | 1000 | 80 | 1600 | 1000 | 50 | | | |
| 1600 | 1000 | 200 | 1600 | 1000 | 200 | 1600 | 1000 | 150 | 1600 | 1000 | 100 | 1600 | 1000 | 80 | 1600 | 1000 | 50 | | | |

Continued from previous page

Continued next page

DN 15-50



| | |
|---------------------|---|
| Media | Cold, hot and steam system Water with glycol up to max. 50% vol. |
| Medium temperature | 0...180°C |
| Pipe connection | Flange PN 25 (ISO 7005-2) |
| Flow characteristic | A-AB equal percentage |
| Leakage rate | Max. 0.01% of k_{VS} value |



Closed cold and hot water systems

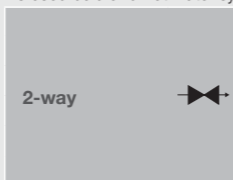

| DN 15 | |
|-----------------|-----------------|
| k_{VS} [m³/h] | Valve type |
| 0.63 | EXT-TI-H615XS-E |
| 1.0 | EXT-TI-H615XS-F |
| 1.5 | EXT-TI-H615XS-G |
| 2.5 | EXT-TI-H615XS-H |
| 4 | EXT-TI-H615XS-J |

Suitable Actuators

- Actuating force
- Actuating time per nominal stroke
- Actuating time for emergency control function
- Open-close
- 3-point
- Modulating (0.5...10 VDC)
- Modulating (2...10 VDC)
- MP-Bus® communication
- Fail-safe function
- Nominal voltage AC/DC 24 V AC 230 V

Standard actuators

| | | | | Actuator type | | Δp_s [kPa] | Δp_{max} [kPa] |
|--------|-------|-----|-----|---------------|--------------|--------------------|------------------------|
| 1000 N | 150 s | • • | • • | 24 V | NV24A-TPC | 1000 | 500 |
| | | | | 230 V | NV230A-TPC | 1000 | 500 |
| | | | | 24 V | NV24A-SZ-TPC | 1000 | 500 |
| | | | | 24 V | NV24A-MP-TPC | 1000 | 500 |
| 1500 N | 150 s | • • | • • | 24 V | SV24A-TPC | | |
| | | | | 230 V | SV230A-TPC | | |
| | | | | 24 V | SV24A-SZ-TPC | | |
| | | | | 24 V | SV24A-MP-TPC | | |

Actuators with fail-safe function NC / NO

| | | | | Actuator type | | Δp_s 2-way [kPa] | Δp_{max} 2-way [kPa] |
|--------|-------|------|-----|---------------|-------|--------------------------|------------------------------|
| 1000 N | 150 s | 35 s | • • | • • | 24 V | NVK24A-3-TPC | 1000 |
| | | | | • • | 230 V | NVK230A-3 | 1000 |
| | | | | • • | 24 V | NVK24A-MP-TPC | 1000 |
| 1500 N | 150 s | 35 s | • • | • • | 24 V | SVK24A-3-TPC* | |
| | | | | • • | 230 V | SVK230-3* | |
| | | | | • • | 24 V | SVK24A-MP-TPC* | |

* Only available through VC.



Continued next page

| DN 20 | | DN 25 | | DN 32 | | DN 40 | | DN 50 | |
|-----------------|-----------------|-----------------|-----------------|-----------------|-----------------|-----------------|------------------|-----------------|------------------|
| k_{VS} [m³/h] | Valve type | k_{VS} [m³/h] | Valve type | k_{VS} [m³/h] | Valve type | k_{VS} [m³/h] | Valve type | k_{VS} [m³/h] | Valve type |
| 6.3 | EXT-TI-H620XS-K | 10 | EXT-TI-H625XS-L | 16 | EXT-TI-H632XS-M | 25 | EXT-TI-H640XSP-N | 40 | EXT-TI-H650XSP-P |

| Δp_s [kPa] | Δp_{max} [kPa] | Δp_s [kPa] | Δp_{max} [kPa] | Δp_s [kPa] | Δp_{max} [kPa] | Δp_s [kPa] | Δp_{max} [kPa] | Δp_s [kPa] | Δp_{max} [kPa] |
|--------------------|------------------------|--------------------|------------------------|--------------------|------------------------|--------------------|------------------------|--------------------|------------------------|
| 1000 | 400 | 1000 | 350 | 600 | 300 | | | | |
| 1000 | 400 | 1000 | 350 | 600 | 300 | | | | |
| 1000 | 400 | 1000 | 350 | 600 | 300 | | | | |
| 1000 | 400 | 1000 | 350 | 600 | 300 | | | | |
| | | | | 1000 | 500 | 1600 | 1000 | 1600 | 1000 |
| | | | | 1000 | 500 | 1600 | 1000 | 1600 | 1000 |
| | | | | 1000 | 500 | 1600 | 1000 | 1600 | 1000 |
| | | | | 1000 | 500 | 1600 | 1000 | 1600 | 1000 |

Continued from previous page

DN 65 – 250



| | |
|---------------------|---|
| Media | Cold, hot and steam system Water with glycol up to max. 50% vol. |
| Medium temperature | 0...180°C |
| Pipe connection | Flange PN 25 (ISO 7005-2) |
| Flow characteristic | A-AB equal percentage |
| Leakage rate | Max. 0.01% of k_{vs} value |

Suitable Actuators

- Actuating force
- Actuating time per nominal stroke
- Actuating time for emergency control function
- Open-close
- 3-point
- Modulating (0.5...10 VDC)
- Modulating (2...10 VDC)
- MP-Bus® communication
- Fail-safe function
- Nominal voltage AC/DC 24 V AC 230 V



Closed cold and hot water systems

2-way

| DN 65 | |
|-----------------|------------------|
| k_{vs} [m³/h] | Valve type |
| 63 | EXT-TI-H665XSP-Q |

Standard actuators

| Actuating force | Actuating time per nominal stroke | Actuating time for emergency control function | Open-close | 3-point | Modulating (0.5...10 VDC) | Modulating (2...10 VDC) | MP-Bus® communication | Fail-safe function | Nominal voltage AC/DC 24 V AC 230 V | Actuator type | | Δp_s [kPa] | Δp_{max} [kPa] |
|-----------------|-----------------------------------|---|------------|---------|---------------------------|-------------------------|-----------------------|--------------------|-------------------------------------|---------------|--------------|--------------------|------------------------|
| | | | | | | | | | | 24 V | 230 V | | |
| 1500 N | 150 s | | | | | | | | | 24 V | SV24A-TPC | 1600 | 1000 |
| | | | | | | | | | | 230 V | SV230A-TPC | 1600 | 1000 |
| | | | | | | | | | | 24 V | SV24A-SZ-TPC | 1600 | 1000 |
| | | | | | | | | | | 24 V | SV24A-MP-TPC | 1600 | 1000 |
| 2500 N | 150 s | | | | | | | | | 24 V | EV24A-TPC | | |
| | | | | | | | | | | 230 V | EV230A-TPC | | |
| | | | | | | | | | | 24 V | EV24A-SZ-TPC | | |
| | | | | | | | | | | 24 V | EV24A-MP-TPC | | |
| 4500 N | 150 s | | | | | | | | | 24 V | RV24A-SZ | | |
| | | | | | | | | | | 24 V | RV24A-MF | | |

Actuators with fail-safe function NC / NO

| Actuating force | Actuating time per nominal stroke | Actuating time for emergency control function | Open-close | 3-point | Modulating (0.5...10 VDC) | Modulating (2...10 VDC) | MP-Bus® communication | Fail-safe function | Nominal voltage AC/DC 24 V AC 230 V | Actuator type | | Δp_s 2-way [kPa] | Δp_{max} 2-way [kPa] |
|-----------------|-----------------------------------|---|------------|---------|---------------------------|-------------------------|-----------------------|--------------------|-------------------------------------|---------------|----------------|--------------------------|------------------------------|
| | | | | | | | | | | 24 V | 230 V | | |
| 1500 N | 150 s | 35 s | | | | | | | | 24 V | SVK24A-3-TPC* | 1600 | 1000 |
| | | | | | | | | | | 230 V | SVK230-3* | 1600 | 1000 |
| | | | | | | | | | | 24 V | SVK24A-MP-TPC* | 1600 | 1000 |
| 2000 N | 150 s | 35 s | | | | | | | | 24 V | AVK24AX-3* | | |
| | | | | | | | | | | 230 V | AVK230A-3 | | |
| 2500 N | 150 s | 35 s | | | | | | | | 24 V | AVK24A-MP-TPC | | |
| | | | | | | | | | | 24 V | EVK24A-3-TPC | | |
| | | | | | | | | | | 230 V | EVK230A-3 | | |
| | | | | | | | | | | 24 V | EVK24A-MP-TPC | | |

* Only available through VC.

| DN 80 | | DN 100 | | DN 125 | | DN 150 | | DN 200 | | DN 250 | |
|-----------------|------------------|-----------------|-------------------|-----------------|-------------------|-----------------|-------------------|-----------------|-------------------|-----------------|-------------------|
| k_{vs} [m³/h] | Valve type | k_{vs} [m³/h] | Valve type | k_{vs} [m³/h] | Valve type | k_{vs} [m³/h] | Valve type | k_{vs} [m³/h] | Valve type | k_{vs} [m³/h] | Valve type |
| 100 | EXT-TI-H680XSP-R | 160 | EXT-TI-H6100XSP-S | 250 | EXT-TI-H6125XSP-T | 350 | EXT-TI-H6150XSP-T | 520 | EXT-TI-H6200XSP-U | 700 | EXT-TI-H6250XSP-V |

| Δp_s [kPa] | Δp_{max} [kPa] | Δp_s [kPa] | Δp_{max} [kPa] | Δp_s [kPa] | Δp_{max} [kPa] | Δp_s [kPa] | Δp_{max} [kPa] | Δp_s [kPa] | Δp_{max} [kPa] | Δp_s [kPa] | Δp_{max} [kPa] | Δp_s [kPa] | Δp_{max} [kPa] |
|--------------------|------------------------|--------------------|------------------------|--------------------|------------------------|--------------------|------------------------|--------------------|------------------------|--------------------|------------------------|--------------------|------------------------|
| 1600 | 1000 | 1600 | 1000 | 1600 | 1000 | 1600 | 1000 | 1600 | 1000 | 1600 | 1000 | 1600 | 1000 |
| 1600 | 1000 | 1600 | 1000 | 1600 | 1000 | 1600 | 1000 | 1600 | 1000 | 1600 | 1000 | 1600 | 1000 |
| 1600 | 1000 | 1600 | 1000 | 1600 | 1000 | 1600 | 1000 | 1600 | 1000 | 1600 | 1000 | 1600 | 1000 |
| 1600 | 1000 | 1600 | 1000 | 1600 | 1000 | 1600 | 1000 | 1600 | 1000 | 1600 | 1000 | 1600 | 1000 |
| 1600 | 1000 | 1600 | 1000 | 1600 | 1000 | 1600 | 1000 | 1600 | 1000 | 1600 | 1000 | 1600 | 1000 |
| 1600 | 1000 | 1600 | 1000 | 1600 | 1000 | 1600 | 1000 | 1600 | 1000 | 1600 | 1000 | 1600 | 1000 |
| 1600 | 1000 | 1600 | 1000 | 1600 | 1000 | 1600 | 1000 | 1600 | 1000 | 1600 | 1000 | 1600 | 1000 |
| 1600 | 1000 | 1600 | 1000 | 1600 | 1000 | 1600 | 1000 | 1600 | 1000 | 1600 | 1000 | 1600 | 1000 |

Continued next page

Continued from previous page

5

Ball valves

Open-close and change-over application

| | | | | |
|-----------------|-------|---------------|-----------|----|
| Internal thread | 2-way | PN 25 / PN 40 | DN 15–50 | 34 |
| | 3-way | | | |
| Flange | 2-way | PN 16 | DN 65–150 | 36 |

DN 65 – 150

| | |
|---------------------|---|
| Media | Cold and hot water with up to max. 50% glycol |
| Medium temperature | -5...100°C |
| Pipe connection | Flange PN 16 |
| Flow characteristic | A-AB, equal percentage |
| Leakage rate | Leakage rate A, tight (EN 12266-1) |



Closed water circuit

| DN 65 | | DN 80 | |
|--------------------|------------|--------------------|------------|
| k_{vs} [m³/h] | Valve type | k_{vs} [m³/h] | Valve type |
| 120 | R665AO | 180 | R680AO |

Suitable Actuators

| Nominal torque | Open-close | 3-point | Fail-safe function | Nominal voltage AC/DC 24 V AC 230 V | Running time motor 90° | Running time emergency control function | Auxiliary switch SPDT |
|----------------|------------|---------|--------------------|---|------------------------|---|-----------------------|
| 20 Nm | • | • | | 24 V | 90 s | | |
| 40 Nm | • | • | | 24 V | 150 s | | |
| 40 Nm | • | • | • | 230 V | | | |

| Standard actuators | | | | | | | | Actuator type | | | |
|--------------------|-------|---|---|-------|-------|--|--|-----------------------|--------------------------------|-----------------------|--------------------------------|
| | | | | | | | | Δp_s [kPa] | $\Delta p_{max}^{1)}$ [kPa] | Δp_s [kPa] | $\Delta p_{max}^{1)}$ [kPa] |
| SR.. | 20 Nm | • | • | 24 V | 90 s | | | 700 | 350 | 700 | 350 |
| | | • | • | 230 V | | | | 700 | 350 | 700 | 350 |
| GR.. | 40 Nm | • | | 24 V | 150 s | | | | | | |
| | | • | | 230 V | | | | | | | |

| Fast running actuators | | | | | | | | Actuator type | | | |
|------------------------|-------|---|--|------|---------|--|--|-----------------------|--------------------------------|-----------------------|--------------------------------|
| | | | | | | | | Δp_s [kPa] | $\Delta p_{max}^{1)}$ [kPa] | Δp_s [kPa] | $\Delta p_{max}^{1)}$ [kPa] |
| SRQ..AX.. | 16 Nm | • | | 24 V | 7..15 s | | | 700 | 350 | | |

| Actuators with fail-safe function NC / NO | | | | | | | | Actuator type | | | |
|---|-------|---|---|------------------------------|-------|-------|---|-----------------------|--------------------------------|-----------------------|--------------------------------|
| | | | | | | | | Δp_s [kPa] | $\Delta p_{max}^{1)}$ [kPa] | Δp_s [kPa] | $\Delta p_{max}^{1)}$ [kPa] |
| SRFA.. | 20 Nm | • | • | AC 24...240V DC 24...125V | <75 s | <20 s | 2 | 700 | 350 | 700 | 350 |
| | | • | • | | | | | 700 | 350 | 700 | 350 |
| GRK.. | 40 Nm | • | • | 24 V | 150 s | 35 s | | | | | |

* Only available via VC.
1) Low-noise operation $\Delta p_{max} = 200$ kPa.

| DN 100 | | DN 125 | | DN 150 | |
|--------------------|------------|--------------------|------------|--------------------|------------|
| k_{vs} [m³/h] | Valve type | k_{vs} [m³/h] | Valve type | k_{vs} [m³/h] | Valve type |
| 230 | R6100AO | 390 | R6125AO | 570 | R6150AO |

| Δp_s [kPa] | $\Delta p_{max}^{1)}$ [kPa] | Δp_s [kPa] | $\Delta p_{max}^{1)}$ [kPa] | Δp_s [kPa] | $\Delta p_{max}^{1)}$ [kPa] |
|-----------------------|--------------------------------|-----------------------|--------------------------------|-----------------------|--------------------------------|
| 700 | 350 | 700 | 350 | 400 | 250 |
| 700 | 350 | 700 | 350 | 400 | 250 |

| Δp_s [kPa] | $\Delta p_{max}^{1)}$ [kPa] | Δp_s [kPa] | $\Delta p_{max}^{1)}$ [kPa] | Δp_s [kPa] | $\Delta p_{max}^{1)}$ [kPa] |
|-----------------------|--------------------------------|-----------------------|--------------------------------|-----------------------|--------------------------------|
| 700 | 350 | 700 | 350 | 400 | 250 |

Continued next page

Continued from previous page

6

Butterfly valves

Open-close, change-over and control applications

| | | | |
|--------------|---|--------------------------|----|
| 2-way flange | Open-close and modulating control of cold and hot water applications | PN 6, 10, 16 / DN 25–300 | 40 |
| | | PN 10, 16 / DN 350–600 | 44 |
| | | PN 16 / DN 700–1200 | 46 |
| 2-way flange | Open-close and modulating control of cold and hot water applications | PN 25 / DN 50-500 | 48 |
| 2-way flange | Open-close and modulating control of sea water and brine applications | PN 16 / DN 50-600 | 50 |
| 2-way flange | Manual operation of cold and hot water applications | PN 6, 10, 16 / DN 25–300 | 54 |
| | | PN 10, 16 / DN 350–600 | |
| | | PN 25 / DN 50–500 | |
| | | PN 16 / DN 50–600 | |

DN 25–300



| | |
|--------------------|--|
| Media | Cold and warm water, water with glycol up to max. 50% vol. |
| Medium temperature | -20...120°C |
| Pipe connection | Flange (ISO 7005-2 and EN 1092-2) D6..W / WL additionally: as per ISO 7005-1 and EN 1092-1 |
| Leakage rate | A, tight (EN 12266-1) |
| PN 6, 10, 16 | DN 25 – 300 wafer types |
| PN 10, 16 | DN 25 – 150 lug types |
| PN 16 | DN 200 – 300 |

| | | | |
|-----------------------------|-------------------------------|-------|-------|
| For open-close applications | k_{vmax} [m³/h] | DN 25 | DN 32 |
| For control applications | k_{vg} ¹⁾ [m³/h] | 50 | 55 |
| | | 24 | 25 |



With wafer type flanges

| | |
|---------|---------|
| BV type | BV type |
| D625N | D632N |



With lug type flanges

| | |
|---------|---------|
| BV type | BV type |
| D625NL | D632NL |

Suitable Actuators

| Nominal torque | Open-close | 3-point | Modulating | Terminal connection | Nominal voltage AC/DC 24 V AC 230 V | Running time motor 90° | Auxiliary switch SPDT | IP rating |
|----------------|------------|---------|------------|---------------------|---|------------------------|-----------------------|-----------|
|----------------|------------|---------|------------|---------------------|---|------------------------|-----------------------|-----------|

Standard actuators

| SR.. | 20 Nm | • | • | • | 24 V | 90 s | IP 54 | Actuator type | Modulating | Δp_s | Δp_s |
|------|--------|---|---|---|-------|-------|-------|---------------------------|---------------------------|--------------|--------------|
| | | | | | | | | open-close / 3-point | (0/2...10 VDC) | [kPa] | [kPa] |
| GR.. | 40 Nm | • | • | • | 24 V | 150 s | IP 54 | SR24A-5 | SR24A-SR-5 | 1200 | 1200 |
| | | | | | 230 V | | | SR230A-5 | SR230A-SR-5 | 1200 | 1200 |
| | | | | | 24 V | | | SR24P-5 | SR24P-SR-5 | 1200 | 1200 |
| | | | | | 230 V | | | SR230P-5 | | 1200 | 1200 |
| | | | | | 24 V | | | GR24A-5 | GR24A-SR-5 | 1200 | 1200 |
| | | | | | 230 V | | | GR230A-5 | | 1200 | 1200 |
| DR.. | <90 Nm | • | • | • | 24 V | 150 s | IP 54 | GR230A-5-CA ²⁾ | | | |
| | | | | | 230 V | | | GR24G-T-5 | GR24G-MF-T-5 | 1200 | 1200 |
| | | | | | 24 V | | | DR24A-5 | DR24A-SR-5 DR24A-MP-5 | | |
| | | | | | 230 V | | | DR230A-5 | | | |
| | | | | | 24 V | | | DR24G-T-5 | DR24G-MF-T-5 | | |
| | | | | | 230 V | | | DR230G-T-5 | | | |
| | | | | | 24 V | | | IP 66/67 | DR24A-7 DR24A-MP-7 | | |
| | | | | | 230 V | | | IP 54 | DR230A-7 | | |
| | | | | | 24 V | | | IP 54 | DR230A-7-CA ²⁾ | | |
| | | | | | 230 V | | | IP 66/67 | DR24G-T-7 DR24G-MF-T-7 | | |
| | | | | | 24 V | | | IP 66/67 | DR230G-T-7 | | |
| | | | | | 230 V | | | IP 66/67 | DR230G-T-7 | | |

Continued next page

| DN 40 | DN 50 | DN 65 | DN 80 | DN 100 | DN 125 | DN 150 | DN 200 | DN 250 | DN 300 |
|-------|-------|-------|-------|--------|--------|--------|--------|--------|--------|
| 65 | 100 | 170 | 260 | 520 | 880 | 1400 | 2200 | 4200 | 5700 |
| 27 | 30 | 50 | 75 | 150 | 200 | 400 | 820 | 1300 | 1740 |

| | | | | | | | | | |
|---------|---------|---------|---------|---------|---------|---------|---------|---------|---------|
| BV type | BV type | BV type | BV type | BV type | BV type | BV type | BV type | BV type | BV type |
| D640N | D650N | D665N | D680N | D6100N | D6125N | D6150N | D6200W | D6250W | D6300W |

| | | | | | | | | | |
|---------|---------|---------|---------|---------|---------|---------|---------|---------|---------|
| BV type | BV type | BV type | BV type | BV type | BV type | BV type | BV type | BV type | BV type |
| D640NL | D650NL | D665NL | D680NL | D6100NL | D6125NL | D6150NL | D6200WL | D6250WL | D6300WL |

| Δp_s | Δp_s | Δp_s | Δp_s | Δp_s | Δp_s | Δp_s | Δp_s | Δp_s | Δp_s |
|--------------|--------------|--------------|--------------|--------------|--------------|--------------|--------------|--------------|--------------|
| [kPa] | [kPa] | [kPa] | [kPa] | [kPa] | [kPa] | [kPa] | [kPa] | [kPa] | [kPa] |
| 1200 | 1200 | 1200 | | | | | | | |
| 1200 | 1200 | 1200 | | | | | | | |
| 1200 | 1200 | 1200 | | | | | | | |
| 1200 | 1200 | 1200 | | | | | | | |
| 1200 | 1200 | 1200 | 1200 | | | | | | |
| 1200 | 1200 | 1200 | 1200 | | | | | | |
| | | | | 1000 | | | | | |
| 1200 | 1200 | 1200 | 1200 | | | | | | |
| 1200 | 1200 | 1200 | 1200 | | | | | | |
| | | | | | 1200 | 1200 | | | |
| | | | | | 1200 | 1200 | | | |
| | | | | | 1200 | 1200 | | | |
| | | | | | | | 1200 | | |
| | | | | | | | 1000 | | |
| | | | | | | | | 1200 | |
| | | | | | | | | 1200 | |

Continued from previous page

¹⁾ With opening angle 60%
²⁾ Cold water applications only

DN 25 – 300



| | |
|--------------------|--|
| Media | Cold and warm water, water with glycol up to max. 50% vol. |
| Medium temperature | -20...120°C |
| Pipe connection | Flange (ISO 7005-2 and EN 1092-2) D6..W / WL additionally: as per ISO 7005-1 and EN 1092-1 |
| Leakage rate | A, tight (EN 12266-1) |
| PN 6, 10, 16 | DN 25 – 300 wafer types |
| PN 10, 16 | DN 25 – 150 lug types |
| PN 16 | DN 200 – 300 |

| | | |
|---|-------|-------|
| | DN 25 | DN 32 |
| For open-close applications k_{vmax} [m³/h] | 50 | 55 |
| For control applications k_{vs} [m³/h] | 24 | 25 |



With wafer type flanges



| | | |
|--|---------|---------|
| | BV type | BV type |
| | D625N | D632N |



With lug type flanges



| | | |
|--|---------|---------|
| | BV type | BV type |
| | D625NL | D632NL |

Suitable Actuators

| | Nominal torque | Open-close | 3-point | Modulating | Terminal connection | Fail-safe function | Nominal voltage | Running time motor 90° | Auxiliary switch SPDT | IP rating |
|--|----------------|------------|---------|------------|---------------------|--------------------|--------------------------------|------------------------|-----------------------|-----------|
| | 40 Nm | • | • | • | • | • | 24 V 230 V | 35 s | | IP 54 |
| | <90 Nm | • | • | • | • | • | 24 V 230 V | 35 s | | IP 54 |
| | 90 Nm | • | • | • | • | • | AC 24...240 V DC 24...125 V | 35 s | 2 | IP 66/67 |
| | 160 Nm | • | • | • | • | • | AC 24...240 V DC 24...125 V | 35 s | 2 | IP 66/67 |

| Fast Runners | | Actuator type open-close / 3-point | Modulating (0/2...10 VDC) | Δp_s [kPa] | Δp_s [kPa] | | | | | |
|------------------------|--------|------------------------------------|---------------------------|--------------------|-------------------------------------|-------|---|---|--------------------------------|------------------------|
| | 40 Nm | • | • | 24 V | IP 54 GRC24A-5 | | | | | |
| | | | | | IP 54 GRC230A-5 | | | | | |
| | | | | | IP 66/67 GRC24G-5 | | | | | |
| | | | | | IP 66/67 GRC230G-5 | | | | | |
| | <90 Nm | • | • | 24 V | IP 54 DRC24A-5 | | | | | |
| | | | | | IP 54 DRC230A-5 | | | | | |
| | | | | | IP 66/67 DRC24G-5 | | | | | |
| | | | | | IP 66/67 DRC230G-5 | | | | | |
| | | | | | IP 54 DRC24A-7 | | | | | |
| | | | | | IP 54 DRC230A-7 | | | | | |
| | | | | | IP 66/67 DRC24G-7 | | | | | |
| | | | | | IP 66/67 DRC230G-7 | | | | | |
| | | | | | IP 66/67 DRC230G-7-CA ⁵⁾ | | | | | |
| | | | | | | 90 Nm | • | • | AC 24...240 V DC 24...125 V | IP 66/67 JRCA-S2-T |
| | | | | | | | | | | IP 66/67 PRCA-S2-T |
| | | | | | | | | | | IP 66/67 PRCA-S2-T-200 |
| IP 66/67 PRCA-S2-T-250 | | | | | | | | | | |

| Actuator with fail-safe function NC / NO | | Actuator type open-close / 3-point | Modulating (0/2...10 VDC) | Δp_s [kPa] | Δp_s [kPa] |
|--|--------|------------------------------------|---------------------------|--------------------------------|-----------------------------|
| | 20 Nm | • | • | 24 V | IP 54 SRF24A-SR-5 |
| | | | | | IP 54 SRF24A-S2-5 |
| | | | | | IP 54 SRFA-5 |
| | | | | | IP 54 SRFA-S2-5 |
| | 40 Nm | • | • | 24 V | IP 54 GRK24A-MF-5 |
| | | | | | IP 54 DRK24A-5 |
| | <90 Nm | • | • | 24 V | IP 54 DRK24A-7 |
| | | | | | IP 66/67 PRKCA-BAC-S2-T |
| | 160 Nm | • | • | AC 24...240 V DC 24...125 V | IP 66/67 PRKCA-BAC-S2-T-200 |
| | | | | | IP 66/67 PRKCA-BAC-S2-T-250 |
| | | | | | IP 66/67 PRKCA-BAC-S2-T-250 |

* With opening angle 60°
1) Linkage: ZPR03
2) Linkage: ZPR01
3) Linkage: ZJR03
4) Linkage: ZJR01
5) Cold water applications only

| | | | | | | | | | | | | |
|-------|-------|-------|-------|--------|--------|--------|--------|--------|--------|--------|--------|--------|
| DN 40 | DN 50 | DN 65 | DN 80 | DN 100 | DN 125 | DN 150 | DN 100 | DN 125 | DN 150 | DN 200 | DN 250 | DN 300 |
| 65 | 100 | 170 | 260 | 520 | 880 | 1400 | 690 | 990 | 1780 | 2200 | 4200 | 5700 |
| 27 | 30 | 50 | 75 | 150 | 260 | 400 | 220 | 310 | 550 | 820 | 1300 | 1740 |

| | | | | | | | | | | | | |
|---------|---------|---------|---------|---------|---------|---------|---------|---------|---------|---------|---------|---------|
| BV type | BV type | BV type | BV type | BV type | BV type | BV type | BV type | BV type | BV type | BV type | BV type | BV type |
| D640N | D650N | D665N | D680N | D6100N | D6125N | D6150N | D6100W | D6125W | D6150W | D6200W | D6250W | D6300W |

| | | | | | | | | | | | | |
|---------|---------|---------|---------|---------|---------|---------|---------|---------|---------|---------|---------|---------|
| BV type | BV type | BV type | BV type | BV type | BV type | BV type | BV type | BV type | BV type | BV type | BV type | BV type |
| D640NL | D650NL | D665NL | D680NL | D6100NL | D6125NL | D6150NL | D6100WL | D6125WL | D6150WL | D6200WL | D6250WL | D6300WL |

| Δp_s [kPa] | Δp_s [kPa] | Δp_s [kPa] | Δp_s [kPa] | Δp_s [kPa] | Δp_s [kPa] | Δp_s [kPa] | Δp_s [kPa] | Δp_s [kPa] | Δp_s [kPa] | Δp_s [kPa] | Δp_s [kPa] | Δp_s [kPa] |
|--------------------|--------------------|--------------------|--------------------|--------------------|--------------------|--------------------|--------------------|--------------------|--------------------|--------------------|--------------------|--------------------|
| 1200 | 1200 | 1200 | 1200 | | | | | | | | | |
| 1200 | 1200 | 1200 | 1200 | | | | | | | | | |
| 1200 | 1200 | 1200 | 1200 | | | | | | | | | |
| 1200 | 1200 | 1200 | 1200 | | | | | | | | | |
| | | | | 1000 | | | | | | | | |
| | | | | 1200 | 1200 | | | | | | | |
| | | | | 1200 | 1200 | | | | | | | |
| | | | | 1200 | 1200 | | | | | | | |
| | | | | 1200 | 1200 | | | | | | | |
| | | | | | | 1200 | 1200 | 1200 | | | | |
| | | | | | | 1200 | 1200 | 1200 | | | | |
| | | | | | | | | | 1000 | | | |
| | | | | | | | | | | 1400 ³⁾ | 1400 ⁴⁾ | 1400 ⁴⁾ |
| | | | | | | | | | | | | 1400 ²⁾ |
| | | | | | | | | | | | | 1400 ²⁾ |

| Δp_s [kPa] | Δp_s [kPa] | Δp_s [kPa] | Δp_s [kPa] | Δp_s [kPa] | Δp_s [kPa] | Δp_s [kPa] | Δp_s [kPa] | Δp_s [kPa] | Δp_s [kPa] | Δp_s [kPa] | Δp_s [kPa] | Δp_s [kPa] |
|--------------------|--------------------|--------------------|--------------------|--------------------|--------------------|--------------------|--------------------|--------------------|--------------------|--------------------|--------------------|--------------------|
| 1200 | 1200 | 1200 | | | | | | | | | | |
| 1200 | 1200 | 1200 | | | | | | | | | | |
| 1200 | 1200 | 1200 | | | | | | | | | | |
| 1200 | 1200 | 1200 | | | | | | | | | | |
| 1200 | 1200 | 1200 | | | | | | | | | | |
| 1200 | 1200 | 1200 | 1200 | | | | | | | | | |
| | | | | 1200 | 1200 | | | | | | | |
| | | | | | | 1200 | 1200 | 1200 | 1400 ¹⁾ | 1400 ²⁾ | 1400 ²⁾ | |
| | | | | | | | | | | | | 1400 ²⁾ |
| | | | | | | | | | | | | 1400 ²⁾ |

DN 350 – 600



| | |
|--------------------|--|
| Media | Cold and warm water, water with glycol up to max. 50% vol. |
| Medium temperature | -20...120°C |
| Pipe connection | Flange (ISO 7005-2 and EN 1092-2) |
| Leakage rate | A, tight (EN 12266-1) |
| PN 16 | DN 350 – 600 |

For open-close applications k_{vmax} [m³/h]
For control applications k_{vs} [m³/h]



With wafer type flanges

| | | |
|-----------------------------|--------|--------|
| | DN 350 | DN 400 |
| For open-close applications | 10300 | 14200 |
| For control applications | 3010 | 4140 |

| | | |
|--|---------|---------|
| | BV type | BV type |
| | D6350B | D6400B |



With lug type flanges

| | | |
|--|---------|---------|
| | BV type | BV type |
| | D6350BL | D6400BL |

Suitable Actuators

| | | | | | | | | |
|----------------|------------|---------|------------|---------------------|-----------------------------|------------------------|-----------------------|-----------|
| Nominal torque | Open-close | 3-point | Modulating | Terminal connection | Nominal voltage 230 V AC | Running time motor 90° | Auxiliary switch SPDT | IP rating |
|----------------|------------|---------|------------|---------------------|-----------------------------|------------------------|-----------------------|-----------|

Fast runners

| | | | | | | | | | Actuator type open-close / 3-point | Modulating (0/2...10 VDC) | Δp_s [kPa] | Δp_s [kPa] |
|---------|---|---|---|---|-------|---------------------|---|-------|---------------------------------------|------------------------------|-----------------------|-----------------------|
| 650 Nm | • | • | • | • | 230 V | 38 s ⁸⁾ | 2 | IP 67 | SY6-230-3-T | SY6U230-MF-T | 1000 | |
| 1000 Nm | • | • | • | • | 230 V | 58 s ⁹⁾ | 2 | IP 67 | SY7-230-3-T | SY7U230-MF-T | | 1000 ⁴⁾ |
| 1000 Nm | • | • | • | • | 230 V | 58 s ¹⁰⁾ | 2 | IP 67 | SY7-230-3-T-TS | SY7U230-MF-T-TS | 1000 ³⁾ | 1000 ⁴⁾ |
| 1500 Nm | • | • | • | • | 230 V | 55 s | 2 | IP 67 | SY8-230-3-T-TS | SY8U230-MF-T-TS | | |
| 2000 Nm | • | • | • | • | 230 V | 70 s | 2 | IP 67 | SY9-230A-3-T-TS | SY9U230A-MF-T-TS | | |
| 3500 Nm | • | • | • | • | 230 V | 70 s | 2 | IP 67 | SY12-230A-3-T-TS | SY12U230A-MF-T-TS | | |

Continued next page

| | | | |
|--|--------|--------|--------|
| | DN 450 | DN 500 | DN 600 |
| | 18800 | 24100 | 37300 |
| | 5490 | 7060 | 10900 |

| | | | |
|--|---------|---------|---------|
| | BV type | BV type | BV type |
| | D6450B | D6500B | D6600B |

| | | | |
|--|---------|---------|---------|
| | BV type | BV type | BV type |
| | D6450BL | D6500BL | D6600BL |

| Δp_s [kPa] | Δp_s [kPa] | Δp_s [kPa] |
|-----------------------|-----------------------|-----------------------|
| | | |
| 1000 ⁵⁾ | | |
| | 1000 ⁶⁾ | |
| | | 1000 ⁷⁾ |

Continued from previous page

* With opening angle 60%

- 1) Linkage: ZPR03
- 2) Linkage: ZPR01
- 3) Linkage: ZSY-720
- 4) Linkage: ZSY-721
- 5) Linkage: ZSY-722
- 6) Linkage: ZSY-920
- 7) Linkage: ZSY-921
- 8) Specific data of Modulating model, please refer to the datasheet
- 9) Specific data of Modulating model, please refer to the datasheet
- 10) Specific data of Modulating model, please refer to the datasheet

DN 700 – 1200



| | |
|--------------------|--|
| Media | Cold and warm water, water with glycol up to max. 50% vol. |
| Medium temperature | -20...120°C |
| Pipe connection | Flange (ISO 7005-2 and EN 1092-2) |
| Leakage rate | A, tight (EN 12266-1) |
| PN 16 | DN 700 – 1200 |

Suitable Actuators

| | | | | | | | | |
|----------------|------------|---------|------------|---------------------|-----------------|------------------------|-----------------------|-----------|
| Nominal torque | Open-close | 3-point | Modulating | Terminal connection | Nominal voltage | Running time motor 90° | Auxiliary switch SPDT | IP rating |
|----------------|------------|---------|------------|---------------------|-----------------|------------------------|-----------------------|-----------|

| | | |
|-----------------------------|-------------------|--------|
| For open-close applications | k_{vmax} [m³/h] | DN 700 |
| For control applications | k_{vs} * [m³/h] | DN 700 |



With wafer type flanges

| | |
|---------|---------------|
| DN 700 | 63245 |
| DN 700 | 9155 |
| BV type | EXT-HH-D6700D |



Standard actuators

| | | | | | | | |
|----------|---|---|---|------------|------|---|-------|
| 5000 Nm | • | • | • | 380 V / 3Ø | 75 s | 4 | IP 67 |
| 10000 Nm | • | • | • | 380 V / 3Ø | 75 s | 4 | IP 67 |
| 20000 Nm | • | • | • | 380 V / 3Ø | 75 s | 4 | IP 67 |

| | | |
|------------------------------------|---------------------------|--------------------|
| Actuator type open-close / 3-point | Modulating (0/2...10 VDC) | Δp_s [kPa] |
| EXT-HH-9032/25/JE | EXT-HH-9032/25/KE | 1000 |
| EXT-HH-9033/26/JE | EXT-HH-9032/26/KE | |
| EXT-HH-9034/27/JE | EXT-HH-9032/27/KE | |



Standard actuators

| | | | | | | | |
|----------|---|---|---|------------|------|---|-------|
| 5000 Nm | • | • | • | 415 V / 3Ø | 75 s | 4 | IP 67 |
| 10000 Nm | • | • | • | 415 V / 3Ø | 75 s | 4 | IP 67 |
| 20000 Nm | • | • | • | 415 V / 3Ø | 75 s | 4 | IP 67 |

| | | |
|------------------------------------|---------------------------|--------------------|
| Actuator type open-close / 3-point | Modulating (0/2...10 VDC) | Δp_s [kPa] |
| EXT-HH-9032/25/JF | EXT-HH-9032/25/KF | 1000 |
| EXT-HH-9033/26/JF | EXT-HH-9033/26/KF | |
| EXT-HH-9034/27/JF | EXT-HH-9034/27/KF | |

| DN 800 | DN 900 | DN 1000 | DN 1200 |
|---------------|---------------|----------------|----------------|
| 84970 | 97290 | 115770 | 177740 |
| 11510 | 16200 | 20325 | 29710 |
| BV type | BV type | BV type | BV type |
| EXT-HH-D6800D | EXT-HH-D6900D | EXT-HH-D61000D | EXT-HH-D61200D |

| | | | |
|--------------------|--------------------|--------------------|--------------------|
| Δp_s [kPa] | Δp_s [kPa] | Δp_s [kPa] | Δp_s [kPa] |
| 1000 | | | |
| | 1000 | | |
| | | 1000 | |
| | | | 1000 |

| | | | |
|--------------------|--------------------|--------------------|--------------------|
| Δp_s [kPa] | Δp_s [kPa] | Δp_s [kPa] | Δp_s [kPa] |
| 1000 | | | |
| | 1000 | | |
| | | 1000 | |
| | | | 1000 |

* With opening angle 60%

Continued next page

Continued from previous page

DN 50 – 500



| | |
|--------------------|--|
| Media | Cold and hot water with glycol up to max. 50% vol. |
| Medium temperature | -20...120°C |
| Pipe connection | Flange (ISO 7005-2) |
| Leakage rate | Rate A Bubble tight (ISO 5208) |
| PN 25 | DN 50 – 500 lug types |

Suitable Actuators

| Nominal torque | Open-close | 3-point | Modulating | Terminal connection | Fail-safe function | Nominal voltage | Running time motor 90° | Auxiliary switch SPDT | IP Rate |
|----------------|------------|---------|------------|---------------------|--------------------|-----------------|------------------------|-----------------------|---------|
|----------------|------------|---------|------------|---------------------|--------------------|-----------------|------------------------|-----------------------|---------|

For open-close applications K_{vmax} [m³/h]
For control applications K_{vs}^* [m³/h]



With lug type flanges

| | DN50 | DN65 |
|---|------|------|
| For open-close applications K_{vmax} [m³/h] | 80 | 155 |
| For control applications K_{vs}^* [m³/h] | 60 | 95 |

| Standard actuators | | | | | | | | | | Actuator type open-close / 3-point | Modulating (0/2...10 VDC) | Δp_s [kPa] | Δp_s [kPa] |
|--------------------|----------|---|---|---|---|------------|-------|---|----------|------------------------------------|---------------------------|--------------------|--------------------|
| GR.. | 40 Nm | • | • | • | • | 24 V | 150 s | 2 | IP 54 | GR24A-5 | GR24A-SR-5 | 2200 | 2200 |
| | | | | | | 230 V | | | IP 54 | GR230A-5 | 2200 | 2200 | |
| | | | | | | 24 V | | | IP 66/67 | GR24G-T-5 | GR24G-MF-T-5 | 2200 | 2200 |
| | | | | | | 230 V | | | IP 66/67 | GR230G-T-5 | 2200 | 2200 | |
| SY.. | 400 Nm | • | • | • | • | 24 V | 20 s | 2 | IP 67 | SY4-24-3-T | SY4U24-MF-T | | |
| | | | | | | 230 V | | | IP 67 | SY4-230-3-T | SY4U230-MF-T | | |
| EXT.. | 650 Nm | • | • | • | • | 230 V | 40 s | 2 | IP 67 | SY6-230-3-T | SY6U230-MF-T | | |
| | | | | | | 1000 Nm | | | IP 67 | SY7-230-3-T-TS | SY7U230-MF-T-TS | | |
| | | | | | | 1500 Nm | | | IP 67 | SY8-230-3-T-TS | SY8U230-MF-T-TS | | |
| | | | | | | 2500 Nm | | | IP 67 | SY10-230A-3-T-TS | SY10U230A-MF-T-TS | | |
| | | | | | | 3500 Nm | | | IP 67 | SY12-230A-3-T-TS | SY12U230A-MF-T-TS | | |
| EXT.. | 5000 Nm | • | • | • | • | 380 V / 3Ø | 75 s | 2 | IP 67 | EXT-HH-9032/25/JE | EXT-HH-9032/25/KE | | |
| | | | | | | 415 V / 3Ø | | | IP 67 | EXT-HH-9032/25/JF | EXT-HH-9032/25/KF | | |
| EXT.. | 10000 Nm | • | • | • | • | 380 V / 3Ø | 75 s | 2 | IP 67 | EXT-HH-9033/26/JE | EXT-HH-9033/26/KE | | |
| | | | | | | 415 V / 3Ø | | | IP 67 | EXT-HH-9033/26/JF | EXT-HH-9033/26/KF | | |

| Fast runners | | | | | | | | | | Actuator type open-close / 3-point | Modulating (0/2...10 VDC) | Δp_s [kPa] | Δp_s [kPa] |
|--------------|--------|---|---|---|---|---------------|------|---|----------|------------------------------------|---------------------------|--------------------|--------------------|
| GRC.. | 40 Nm | • | • | • | • | 24 V | 35 s | 2 | IP 54 | GRC24A-5 | | 2200 | 2200 |
| | | | | | | 230 V | | | IP 54 | GRC230A-5 | GRC230A-SR-TP-5 | 2200 | 2200 |
| | | | | | | 24 V | | | IP 66/67 | GRC24G-5 | GRC24G-MF-T-5 | 2200 | 2200 |
| | | | | | | 230 V | | | IP 66/67 | GRC230G-5 | GRC230G-SR-TP-5 | 2200 | 2200 |
| JRCA.. | 90 Nm | • | • | • | • | AC 24...240 V | 35 s | 2 | IP 66/67 | JRCA-S2-T | JRCA-BAC-S2-T | | |
| | | | | | | DC 24...125 V | | | | | | | |
| PRCA.. | 160 Nm | • | • | • | • | AC 24...240 V | 35 s | 2 | IP 66/67 | PRCA-S2-T | PRCA-BAC-S2-T | | |
| | | | | | | DC 24...125 V | | | | | | | |

| Actuators with fail-safe function NC / NO | | | | | | | | | | Actuator type open-close / 3-point | Modulating (0/2...10 VDC) | Δp_s [kPa] | Δp_s [kPa] |
|---|--------|---|---|---|---|---------------|-------|---|----------|------------------------------------|---------------------------|--------------------|--------------------|
| GRK.. | 40 Nm | • | • | • | • | 24 V | 150 s | | IP 54 | GRK24A-5 | GRK24A-MF-5 | 2200 | 2200 |
| PRKCA.. | 160 Nm | • | • | • | • | AC 24...240 V | 35 s | 2 | IP 66/67 | PRKCA-BAC-S2-T | PRKCA-BAC-S2-T | | |
| | | | | | | DC 24...125 V | | | | | | | |

* With opening angle 60%
1) Linkage: ZPR03
2) Linkage: ZPR01
3) Linkage: ZSY-722
4) Linkage: ZSY-920
5) Linkage: ZSY-921
6) Linkage: ZJR03

| DN80 | DN100 | DN125 | DN150 | DN200 | DN250 | DN300 | DN350 | DN400 | DN450 | DN500 |
|------|-------|-------|-------|-------|-------|-------|-------|-------|-------|-------|
| 260 | 410 | 780 | 1350 | 2575 | 3825 | 6030 | 7505 | 9720 | 12775 | 16785 |
| 145 | 160 | 345 | 540 | 865 | 1280 | 1815 | 2225 | 3205 | 4090 | 5180 |

| Δp_s [kPa] | Δp_s [kPa] | Δp_s [kPa] | Δp_s [kPa] | Δp_s [kPa] | Δp_s [kPa] | Δp_s [kPa] | Δp_s [kPa] | Δp_s [kPa] | Δp_s [kPa] | Δp_s [kPa] |
|--------------------|--------------------|--------------------|--------------------|--------------------|--------------------|--------------------|--------------------|--------------------|--------------------|--------------------|
| 2200 | | | | | | | | | | |
| 2200 | | | | | | | | | | |
| 2200 | | | | | | | | | | |
| 2200 | | | | | | | | | | |
| | | | 2200 | 2200 | | | | | | |
| | | | 2200 | 2200 | | | | | | |
| | | | | | 2200 | | | | | |
| | | | | | | 2200 ³⁾ | | | | |
| | | | | | | 2200 ³⁾ | | | | |
| | | | | | | | 2200 ⁴⁾ | | | |
| | | | | | | | | 2200 ⁵⁾ | 2200 ⁵⁾ | |
| | | | | | | | | 2200 | 2200 | |
| | | | | | | | | 2200 | 2200 | |
| | | | | | | | | | | 2200 |
| | | | | | | | | | | 2200 |

| Δp_s [kPa] | Δp_s [kPa] | Δp_s [kPa] | Δp_s [kPa] | Δp_s [kPa] | Δp_s [kPa] | Δp_s [kPa] | Δp_s [kPa] | Δp_s [kPa] | Δp_s [kPa] | Δp_s [kPa] |
|--------------------|--------------------|--------------------|--------------------|--------------------|--------------------|--------------------|--------------------|--------------------|--------------------|--------------------|
| 2200 | | | | | | | | | | |
| 2200 | | | | | | | | | | |
| 2200 | | | | | | | | | | |
| 2200 | | | | | | | | | | |
| 2200 ⁶⁾ | | | | | | | | | | |
| | 2200 ¹⁾ | 2200 ²⁾ | | | | | | | | |

| Δp_s [kPa] | Δp_s [kPa] | Δp_s [kPa] | Δp_s [kPa] | Δp_s [kPa] | Δp_s [kPa] | Δp_s [kPa] | Δp_s [kPa] | Δp_s [kPa] | Δp_s [kPa] | Δp_s [kPa] |
|--------------------|--------------------|--------------------|--------------------|--------------------|--------------------|--------------------|--------------------|--------------------|--------------------|--------------------|
| 2200 | | | | | | | | | | |
| | 2200 ¹⁾ | 2200 ²⁾ | | | | | | | | |

DN 50 – 600



| | |
|--------------------|------------------------------------|
| Media | Sea water and brine |
| Medium temperature | Aluminium Bronze disc: -10...+80°C |
| Pipe connection | Flange (ISO 7005-2) |
| Leakage rate | Rate A Bubble tight (ISO 5208) |
| PN 16 | DN 50 – 600 wafer types |

Suitable Actuators

| | | | | | | | | |
|----------------|------------|---------|------------|---------------------|-----------------|------------------------|-----------------------|---------|
| Nominal torque | Open-close | 3-point | Modulating | Terminal connection | Nominal voltage | Running time motor 90° | Auxiliary switch SPDT | IP Rate |
|----------------|------------|---------|------------|---------------------|-----------------|------------------------|-----------------------|---------|

For open-close applications K_{vmax} [m³/h]
For control applications K_{vs}^* [m³/h]



With wafer type flanges

| | DN50 | DN65 | DN80 |
|---|---------------|---------------|---------------|
| For open-close applications K_{vmax} [m³/h] | 85 | 170 | 280 |
| For control applications K_{vs}^* [m³/h] | 40 | 70 | 95 |
| BV type | EXT-HH-D650AB | EXT-HH-D665AB | EXT-HH-D680AB |

Standard actuators

| SR.. | GR.. | DR.. | SY.. | EXT.. | Nominal torque | Voltage | Running time | IP | Actuator type | | Δp_s [kPa] | Δp_s [kPa] | Δp_s [kPa] |
|------|------|------|------|-------|----------------|------------------------|--------------|----------|--|--|--------------------|--------------------|--------------------|
| | | | | | | | | | open-close / 3-point | Modulating (0/2...10 VDC) | | | |
| | | | | | 20 Nm | 24 V | 90 s | IP 54 | SR24A-5 | SR24A-SR-5 | 1200 | | |
| | | | | | 20 Nm | 230 V | 90 s | IP 54 | SR230A-5 | SR230A-SR-5 | 1200 | | |
| | | | | | 20 Nm | 24 V | 150 s | IP 66/67 | SR24P-5 | SR24P-SR-5 | 1200 | | |
| | | | | | 20 Nm | 230 V | 150 s | IP 66/67 | SR230P-5 | | 1200 | | |
| | | | | | 40 Nm | 24 V | 150 s | IP 54 | GR24A-5 | GR24A-SR-5 | | 1200 | |
| | | | | | 40 Nm | 230 V | 150 s | IP 54 | GR230A-5 | | | 1200 | |
| | | | | | 40 Nm | 24 V | 150 s | IP 66/67 | GR24G-T-5 | GR24G-MF-T-5 | | 1200 | |
| | | | | | 40 Nm | 230 V | 150 s | IP 66/67 | GR230G-T-5 | | | 1200 | |
| | | | | | <90 Nm | 24 V | 150 s | IP 54 | DR24A-5 | DR24A-SR-5 DR24A-MP-5 | | | 1200 |
| | | | | | <90 Nm | 230 V | 150 s | IP 54 | DR230A-5 | | | | 1200 |
| | | | | | <90 Nm | 24 V | 150 s | IP 66/67 | DR24G-T-5 | DR24G-MF-T-5 | | | 1200 |
| | | | | | <90 Nm | 230 V | 150 s | IP 66/67 | DR230G-T-5 | | | | 1200 |
| | | | | | <90 Nm | 24 V | 150 s | IP 54 | DR24A-7 | DR24A-SR-7 DR24A-MP-7 | | | |
| | | | | | <90 Nm | 230 V | 150 s | IP 54 | DR230A-7 | | | | |
| | | | | | <90 Nm | 24 V | 150 s | IP 66/67 | DR24G-T-7 | DR24G-MF-T-7 | | | |
| | | | | | <90 Nm | 230 V | 150 s | IP 66/67 | DR230G-T-7 | | | | |
| | | | | | 400 Nm | 24 V | 20 s | IP 67 | SY4-24-3-T | SY4U24-MF-T | | | |
| | | | | | 400 Nm | 230 V | 23 s | IP 67 | SY4-230-3-T | SY4U230-MF-T | | | 1200 |
| | | | | | 1000 Nm | 230 V | 60 s | IP 67 | SY7-230-3-T-TS | SY7U230-MF-T-TS | | | |
| | | | | | 1500 Nm | 230 V | 60 s | IP 67 | SY8-230-3-T-TS | SY8U230-MF-T-TS | | | |
| | | | | | 2000 Nm | 230 V | 76 s | IP 67 | SY9-230A-3-T-TS | SY9U230A-MF-T-TS | | | |
| | | | | | 2500 Nm | 230 V | 76 s | IP 67 | SY10-230A-3-T-TS | SY10U230A-MF-T-TS | | | |
| | | | | | 3500 Nm | 230 V | 76 s | IP 67 | SY12-230A-3-T-TS | SY12U230A-MF-T-TS | | | |
| | | | | | 5000 Nm | 380V / 3Ø 415V / 3Ø | 75 s | IP 67 | EXT-HH-9032/25/JE EXT-HH-9032/25/JF | EXT-HH-9032/25/KE EXT-HH-9032/25/KF | | | |

Continued next page

| DN100 | DN125 | DN150 | DN200 | DN250 | DN300 | DN350 | DN400 | DN450 | DN500 | DN600 |
|--------------------|--------------------|--------------------|--------------------|--------------------|--------------------|--------------------|--------------------|--------------------|--------------------|--------------------|
| 535 | 750 | 1585 | 2645 | 4020 | 7355 | 7935 | 9735 | 12790 | 16800 | 26085 |
| 200 | 225 | 415 | 785 | 1340 | 1605 | 2215 | 3225 | 4100 | 5200 | 7615 |
| BV type | BV type | BV type | BV type | BV type | BV type | BV type | BV type | BV type | BV type | BV type |
| EXT-HH-D6100AB | EXT-HH-D6125AB | EXT-HH-D6150AB | EXT-HH-D6200AB | EXT-HH-D6250AB | EXT-HH-D6300AB | EXT-HH-D6350AB | EXT-HH-D6400AB | EXT-HH-D6450AB | EXT-HH-D6500AB | EXT-HH-D6600AB |
| Δp_s [kPa] | Δp_s [kPa] | Δp_s [kPa] | Δp_s [kPa] | Δp_s [kPa] | Δp_s [kPa] | Δp_s [kPa] | Δp_s [kPa] | Δp_s [kPa] | Δp_s [kPa] | Δp_s [kPa] |
| 1200 | | | | | | | | | | |
| 1200 | | | | | | | | | | |
| 1200 | | | | | | | | | | |
| 1200 | | | | | | | | | | |
| | 1200 | | | | | | | | | |
| | 1200 | | | | | | | | | |
| | 1200 | | | | | | | | | |
| | 1200 | | | | | | | | | |
| | | | | 1200 | 1200 | | | | | |
| | | | | 1200 | 1200 | | | | | |
| | | | | | | 1200 ¹⁾ | 1200 ²⁾ | | | |
| | | | | | | | 1200 ²⁾ | 1200 ³⁾ | | |
| | | | | | | | | 1200 ⁴⁾ | 1200 ⁴⁾ | |
| | | | | | | | | | 1200 ⁴⁾ | |
| | | | | | | | | | | 1200 ⁵⁾ |
| | | | | | | | | | | 1200 |
| | | | | | | | | | | 1200 |

Continued from previous page

* With opening angle 60%
1) Linkage: ZSY-720
2) Linkage: ZSY-721
3) Linkage: ZSY-722
4) Linkage: ZSY-920
5) Linkage: ZSY-921

DN 25– 600

| | |
|--------------------|---|
| Media | Cold and warm water, water with glycol up to 50% vol. |
| Pipe connection | Flange (ISO 7005-2 and EN 1092-2) D6..W / WL additionally: as per ISO 7005-1 and EN 1092-1 |
| Medium temperature | -20...120°C |
| Leakage rate | A, tight (EN 12266-1) |
| PN 6, 10, 16 | DN 25 – 300 wafer types |
| PN 10, 16 | DN 25 – 150 lug types |
| PN 16 | DN 200 – 300 |
| PN 16 | DN 350 – 600 wafer and lug types |

Suitable Manual Handles and Worm Gears

| | DN25 | DN50 | DN65 | DN80 | DN100 | DN125 |
|--------------------------------|--------|--------|--------|--------|---------|---------|
| With wafer type flanges | D625N | D650N | D665N | D680N | D6100N | D6125N |
| With lug type flanges | D625NL | D650NL | D665NL | D680NL | D6100NL | D6125NL |
| Handle | | | | | | |
| ZD6N-H100 | • | • | • | • | • | |
| ZD6N-H150 | | | | | | • |
| Worm Gear | | | | | | |
| ZD6N-S100 | • | • | • | • | • | |
| ZD6N-S150 | | | | | | • |
| ZD6N-S350 | | | | | | |
| ZD6N-S400 | | | | | | |
| ZD6N-S450 | | | | | | |
| ZD6N-S500 | | | | | | |
| ZD6N-S600 | | | | | | |

DN 50 – 500

| | |
|--------------------|-------------------------------------|
| Media | Cold and hot water, Max. 50% glycol |
| Pipe connection | Flange (ISO 7005-2) |
| Medium temperature | -20...120°C |
| Leakage rate | Rate A Bubble tight (ISO 5208) |
| PN 25 | DN 50 – 500 lug types |

Suitable Manual Handles and Worm Gears

| | DN50 | DN65 | DN80 | DN100 |
|------------------------------|--------------|--------------|--------------|---------------|
| With lug type flanges | EXT-HH-D650H | EXT-HH-D665H | EXT-HH-D680H | EXT-HH-D6100H |
| Handle | | | | |
| ZD6N-H100 | • | • | • | • |
| ZD6N-H150 | | | | |
| Worm Gear | | | | |
| ZD6N-S100 | • | • | • | • |
| ZD6N-S150 | | | | |
| ZD6N-S350 | | | | |
| ZD6N-S450 | | | | |
| ZD6N-S500 | | | | |
| ZD6N-S600 | | | | |
| ZN6N-S700 | | | | |

Continued next page

DN 50 – 600

| | |
|--------------------|------------------------------------|
| Media | Sea water and brine |
| Pipe connection | Flange (ISO 7005-2) |
| Medium temperature | Aluminium Bronze disc: -10...+80°C |
| Leakage rate | Rate A Bubble tight (ISO 5208) |
| PN 16 | DN 50 – 600 wafer types |

Suitable Manual Handles and Worm Gears

| | DN50 | DN65 | DN80 | DN100 |
|------------------------------|---------------|---------------|---------------|----------------|
| With lug type flanges | EXT-HH-D650AB | EXT-HH-D665AB | EXT-HH-D680AB | EXT-HH-D6100AB |
| Handle | | | | |
| ZD6N-H100 | • | • | • | • |
| ZD6N-H150 | | | | |
| Worm Gear | | | | |
| ZD6N-S100 | • | • | • | • |
| ZD6N-S150 | | | | |
| ZD6N-S350 | | | | |
| ZD6N-S400 | | | | |
| ZD6N-S450 | | | | |
| ZD6N-S500 | | | | |
| ZD6N-S600 | | | | |

| DN150 | DN100 | DN125 | DN150 | DN200 | DN250 | DN300 | DN350 | DN400 | DN450 | DN500 | DN600 |
|---------|---------|---------|---------|---------|---------|---------|---------|---------|---------|---------|---------|
| D6150N | D6100W | D6125W | D6150W | D6200W | D6250W | D6300W | D6350B | D6400B | D6450B | D6500B | D6600B |
| D6150NL | D6100WL | D6125WL | D6150WL | D6200WL | D6250WL | D6300WL | D6350BL | D6400BL | D6450BL | D6500BL | D6600BL |

Continued from previous page

| DN125 | DN150 | DN200 | DN250 | DN300 | DN350 | DN400 | DN450 | DN500 |
|---------------|---------------|---------------|---------------|---------------|---------------|---------------|---------------|---------------|
| EXT-HH-D6125H | EXT-HH-D6150H | EXT-HH-D6200H | EXT-HH-D6250H | EXT-HH-D6300H | EXT-HH-D6350H | EXT-HH-D6400H | EXT-HH-D6450H | EXT-HH-D6500H |

| DN125 | DN150 | DN200 | DN250 | DN300 | DN350 | DN400 | DN450 | DN500 | DN600 |
|----------------|----------------|----------------|----------------|----------------|----------------|----------------|----------------|----------------|----------------|
| EXT-HH-D6125AB | EXT-HH-D6150AB | EXT-HH-D6200AB | EXT-HH-D6250AB | EXT-HH-D6300AB | EXT-HH-D6350AB | EXT-HH-D6400AB | EXT-HH-D6450AB | EXT-HH-D6500AB | EXT-HH-D6600AB |

k_v The flow coefficient k_v [m^3/h] is the specific volume flow of a valve at a defined positioning angle with reference to 100 kPa (1 bar). The k_v value changes, depending on the valve position. The flow coefficient is determined at a water temperature of 5...40°C.

k_{vs} The k_v value in reference to the nominal positioning angle is referred to as the k_{vs} value. The nominal positioning angle defines the maximum valve opening and is specified by the manufacturer.

| | |
|------------------------------------|---|
| Characterised control valve (CCV): | Flow coefficient at 100% valve opening (90° angle of rotation) |
| Zone valve (QCV): | Flow coefficient at respective position of the end stop clip (adjustable) |
| Globe valves: | Flow coefficient at 100% valve opening |
| Butterfly valves: | Flow coefficient at 60% valve opening for standard application |

$$k_{vs} = \frac{\dot{V}_{100}}{\sqrt{\frac{\Delta p_{v100}}{100}}}$$

Δp_{v100} [kPa]

\dot{V}_{100} [m^3/h]

k_{vs} [m^3/h]

k_{vmax} Flow coefficient for 100% opened butterfly valve for open-close and change-over application.

\dot{V}_{nom} Greatest possible flow rate of a pressure-independent valve, catalogue value, status upon delivery.

\dot{V}_{max} Maximum flow rate of a pressure-independent valve which has been set with the greatest positioning signal, e.g. 10 V.

Δp_{max} Maximum permitted pressure difference for long service life across control path A-AB with respect to the whole range of opening.

Δp_s Maximum closing pressure at which the valve can still seal the fitting tightly in terms of the respective leakage class.

All inclusive.

Belimo as a global market leader develops innovative solutions for the controlling of heating, ventilation and air-conditioning systems. Damper actuators, control valves, sensors and meters represent our core business.

Always focusing on customer value, we deliver more than only products. We offer you the complete product range for the regulation and control of HVAC systems from a single source. At the same time, we rely on tested Swiss quality with a five-year warranty. Our worldwide representatives in over 80 countries guarantee short delivery times and comprehensive support through the entire product life. Belimo does indeed include everything.

The “small” Belimo devices have a big impact on comfort, energy efficiency, safety, installation and maintenance.

In short: Small devices, big impact.



5-year warranty



On site around the globe



Complete product range



Tested quality



Short delivery times



Comprehensive support

